



Division 2 Carryover Sensor

A simple and reliable method of detecting liquid carryover in sample systems

This carryover sensor is designed to detect the presence of liquids such as water, glycol and alcohols in gas phase analyzer sample systems at pressure up to 3450 kPag (500 psig). It functions as a combination of cyclone separator, knock out pot and liquid carryover sensor.

The sample housing has an upper section made from electroless nickel plated aluminum with 1/8" NPT inlet and output ports, with the inlet gas going through a 2 mm diameter orifice and flowing tangentially into a small diameter bore. This inlet geometry results in large centrifugal forces on the gas sample which tends to move denser components such as liquid aerosols and particulates radially outward towards the walls of the housing where they can coalesce. Any liquids or particulates that are separated from the gas collect at the inside bottom of the lower housing, which is made from glass filled PEEK.

A capacitive sensor with non-incendive hazardous area certification for Class I Division 2 is threaded into the bottom of the lower housing and will detect liquids or particulates that collect in the bottom of the housing. The capacitive sensor is isolated from the sample gas by the bottom wall of the housing and can detect accumulated liquid through the wall of the housing because the PEEK has a low dielectric constant, only slightly higher than air.

The capacitive sensor only requires a two-wire connection with power supply of 20 to 250 V AC/DC and has a normally open output function. Sensitivity can be adjusted via a potentiometer on the bottom of the sensor. The sensor output is normally open with minimum and maximum load currents of 5 mA and 200 mA. An external miniature fuse with 2A or less rating should be provided to prevent short circuit situations.

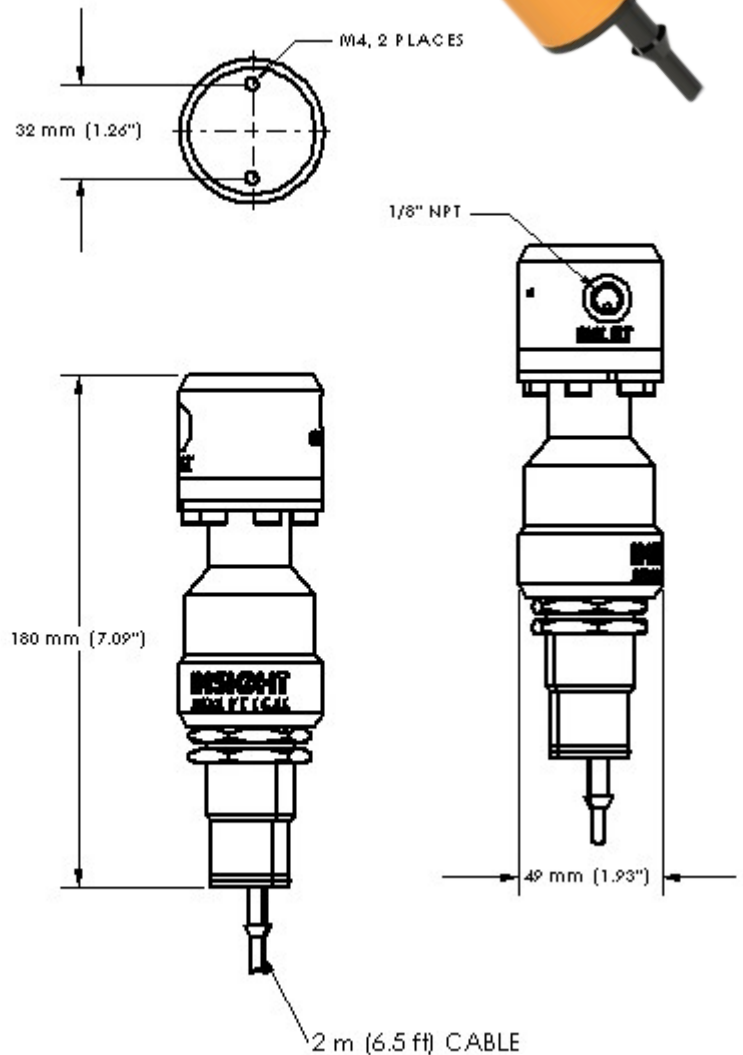

The quantity of liquid required to trip the sensor depends on the dielectric constant, with it generally being very sensitive to water, somewhat less sensitive to glycol and alcohols, and not being able to detect saturated hydrocarbons such as compressor oil. Particulates with high dielectric constants can also be detected, such as metals or metallic compounds.

When mounting the carryover sensor, the sensor and lower part of the housing must be kept at least 75 mm (3") away from conductive materials such as metal fittings, tubing and panels. An optional bracket is available to mount the sensor on a panel. It is also important to keep in mind when working around the sensor that hands or tools will trip the sensor if they get too close.

The housing is NACE MR0175 compliant and can be used in sour gas applications, but should not be used where there are components in the sample that can attack the nickel plated aluminum and PEEK housings such as strong acids including HCl and nitric acid, halogens, carbon disulfide, and phenol.

After a liquid carryover event, the liquid needs to be removed from the lower sensor housing before returning to service. The liquid can be removed by disassembling the housing and cleaning, or alternatively inverting the housing and purging with instrument air. Isopropyl Alcohol or soap and water work well for cleaning the inside of the housings if this is required. Do not use any chemicals for cleaning that may attack PEEK or aluminum, such as strong acids. The inside of the housings should be dry before reassembly. It is recommended that a new o-ring be installed after disassembling the housings for cleaning.

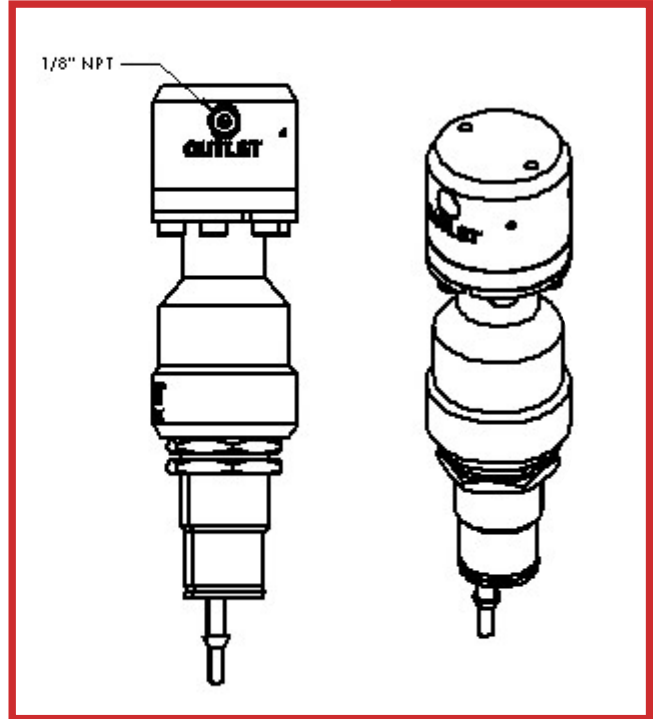

Technical Specifications	
Maximum Pressure Rating	3450 kPag (500 psig) at 40°C maximum 1380 kPag (250 psig) at 60°C maximum 690 kPag (100 psig) at 70°C maximum
Temperature Range	-20°C to 70°C (-4°F to 158°F)
Internal Volume	16 cm ³ (1 in ³)
Inlet and Outlet Port Size	1/8" NPT female thread
Power supply	20 to 250 V AC/DC, with 2A fuse
Hazardous area certifications	CSA Class I, Division 2, Groups A, B, C and D; Class II, Division 2, Groups E, F, and G T4, ambient temperature range -25°C to 70°C. Ingress Protection IP65/Type 4/4X
Wetted Materials	Electroless nickel plated 6061 T6 aluminum, glass filled PEEK, nylon, perfluoroelastomer (FFKM) o-ring.
NACE compliance	NACE MR0175/ISO 15156 and MR0103 Compliant.
Output type	Normally Open, with minimum load current of 5 mA and maximum switching output of 200 mA.
Electrical Connection	2 m PVC cable, 2 x 0.5 mm ² wires