



Half Inch NPT Probe

A simple and economical sample quill probe designed to work in most applications with a ½" NPT threadolet process connection.

The Insight Analytical ½" NPT sample quill probe has a ½" NPT process connection and another male ½" NPT connection for an isolation valve. It is designed for applications with ½" NPT threadolet process connections and has an insertion length of 50 mm from the base of the NPT thread, or about 25 to 38 mm (1 to 1.5 inches) as measured from the inside wall of typical process pipes. This length is sufficient to obtain a representative sample in most applications.

The quill section of the probe has a 1.5 mm bore for fast response time, a hemispherical tip to reject particulates and liquid aerosols, and follows the Insight Analytical philosophy of eliminating excessive probe insertion length. Electropolish the surface, which results in improved corrosion resistance, higher fatigue strength, and reduces the tendency for thread galling.

For most gas phase applications, the common practice of specifying probe length to locate the tip in the center third of the pipe typically results in a probe that is much longer than required to obtain a representative sample. The elimination of excess sample probe length lowers cost, improves response time, makes plugging less likely, reduces pressure drop and flow disturbances in the process pipe, and makes it possible to design the probe to withstand high process gas velocity without failure caused by vortex shedding induced vibration. This probe has been designed to meet the vortex shedding safety calculations in the ASME PTC 19.3 TW-2010 thermowell design standard for fluid velocities up to 100 m/s and fluid densities up to 0.4 kg/m³.

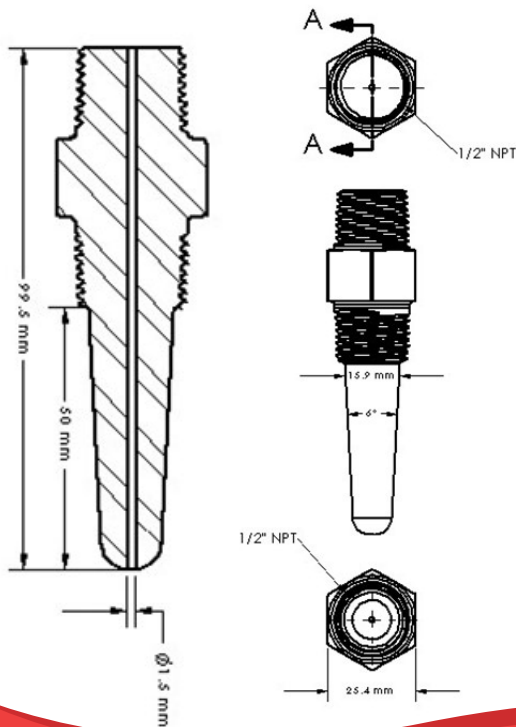

Technical Specifications

Maximum Pressure Rating	20700 kPag (3000 psig)
Temperature Range	-45°C to 149°C (-49°F to 300°F)
Internal Volume	0.18 cm ³ (0.011 in ³)
Outlet Port Size	½" NPT male thread
Process Connection Size	½" NPT male thread
Threadolet Process Connection Required	½" NPT Female thread. Minimum opening ID of 16.5 mm (0.65").
Wetted Materials	Electropolished 316L Stainless Steel
NACE compliance	NACE MR0175/ISO 15156 and MR0103 Compliant.
Compliance with ASME PTC 19.3 TW-2010	Passes calculations for process velocities up to 100 m/s and maximum density of 0.4 kg/m ³

