

Table of contents

	Page
Safety notes/ Technical support	2

Introduction	3

Applications	4

Technical data:	
Dimensions	5
Electrical data	9
Mechanical data	10
Operating conditions	11
Transport and Storage	12

Approvals	13

Options	13

Mounting	14

Electrical installation	20

Quickstart	22

Advanced programming	29

Probe modifications	35

Assembly - Remote version/ FM, FMc Control Drawing	36

Troubleshooting	37

Maintenance	39

Notes for use in Hazardous Locations	41

Disposal	43

Subject to technical change.
 All dimensions in mm (inch).

We assume no liability for typing errors.
 Different variations than specified are possible.
 Please contact our technical consultants.

Safety notes / Technical support

Notes

- Installation, maintenance and commissioning may be accomplished only by qualified technical personnel.
- The product must be used only in the manner outlined in this instruction manual.

Special attention must be paid to warnings and notes as follows:

WARNING



Relates to a caution symbol on the product: A failure to observe the necessary precautions can result in death, serious injury and/ or considerable material damage.

WARNING



Relates to a caution symbol on the product: Risk of electric shock

WARNING





A failure to observe the necessary precautions can result in death, serious injury and/ or considerable material damage.

This symbol is used, when there is no corresponding caution symbol on the product.

CAUTION

A failure to observe the necessary precautions can result in considerable material damage.

Safety symbols

In manual and on product	Description
	CAUTION: refer to accompanying documents (manual) for details.
	Earth (ground) Terminal
	Protective Conductor Terminal

Technical support

Please contact your local supplier (for address see www.uwt.de). Otherwise you can contact:

UWT GmbH
 Westendstr. 5
 D-87488 Betzigau

Tel.: 0049 (0)831 57123-0
 Fax: 0049 (0)831 76879
info@uwt.de
www.uwt.de

Introduction

Applications

The device is used for level monitoring in all types of containers and silos.

It can be used with all powdery and granulated bulk materials, slurry and liquids.

The units can be delivered with Ex-approvals for use in Dust and Gas Hazardous Areas.

A selection of fields of application:

- **Building materials industry**
lime, moulding sand, etc.
- **Food industry**
sugar, flour, salt, etc.
- **Plastics industry**
plastics granules etc.
- **Chemical industry**
pigments
- **Mechanical engineering**

The RFnivo is normally screwed into the lateral container wall at a position, where the material shall be measured.

The device can also be mounted from the top of the container. In this case an extension piece is used to mount the probe level with the height to be measured.

The length of the probe can be up to 2.5 m (98.4") with rod extension or 20 m (787") with rope extension.

The use of a sliding sleeve is recommended so that the switch point can be changed continuously during operation of the device.

Function

The unit detects the capacitance between the probe and the container wall.

The performance allows to use the unit in a wide range of even difficult applications combined with simple handling:

- **Active shield technology**
The powerful active shield technology allows to ignore material build up on the probe. Even the influence of conductive build up on the probe is electronically compensated and thus ignored. This allows to measure with high sensitivity in combination with material build up.
- **Self diagnostics**
The unit is able to check the internal electronic for proper functionality. This can be done by setting a frequent auto test or by pressing a manual test button.
- **Auto calibration**
The unit will auto calibrate to uncovered state after first time power up.

It allows to set for auto recalibration to uncovered state. This is useful in case of a covered probe during power up. An auto recalibration is done when the probe becomes uncovered.

- **Manual recalibration to uncovered state can be done by simply pressing a push button.**
- **Full manual calibration can be selected as well.**

The sensitivity is preselected to work in most applications and can be changed if required.

Applications

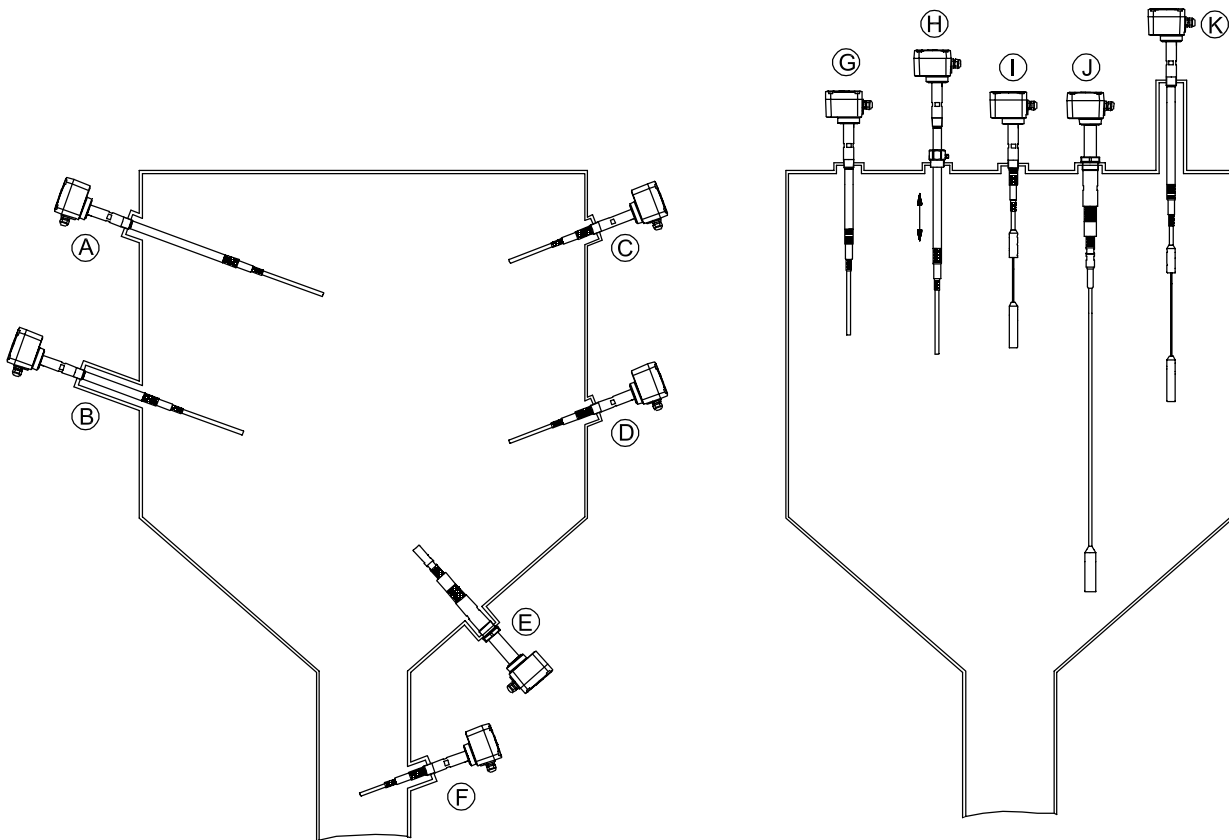

	RF 3100	RF 3200	RF 3300
(A) Inactive length to reach distance from silo wall	•	•	•
(B) Inactive length due to long mounting nozzle	•	•	•
(C) Full detector with short length	•	•	•
(D) Demand detector with short length, observe max. load	•	•	•
(E) Empty detector with short length, observe max. load	•	•	•
(F) Application in down pipe, observe max. load	•	•	•
(G) Inactive length to bring active probe to required level	•	•	•
(H) Inactive length and sliding sleeve for adjustable height	•	•	•
(I) Full detector, rope version	•	•	•
(J) Empty detector, rope version, observe max. load	•	•	•
(K) Inactive length due to long mounting nozzle	•	•	•

Technical data - Dimensions

Housing versions

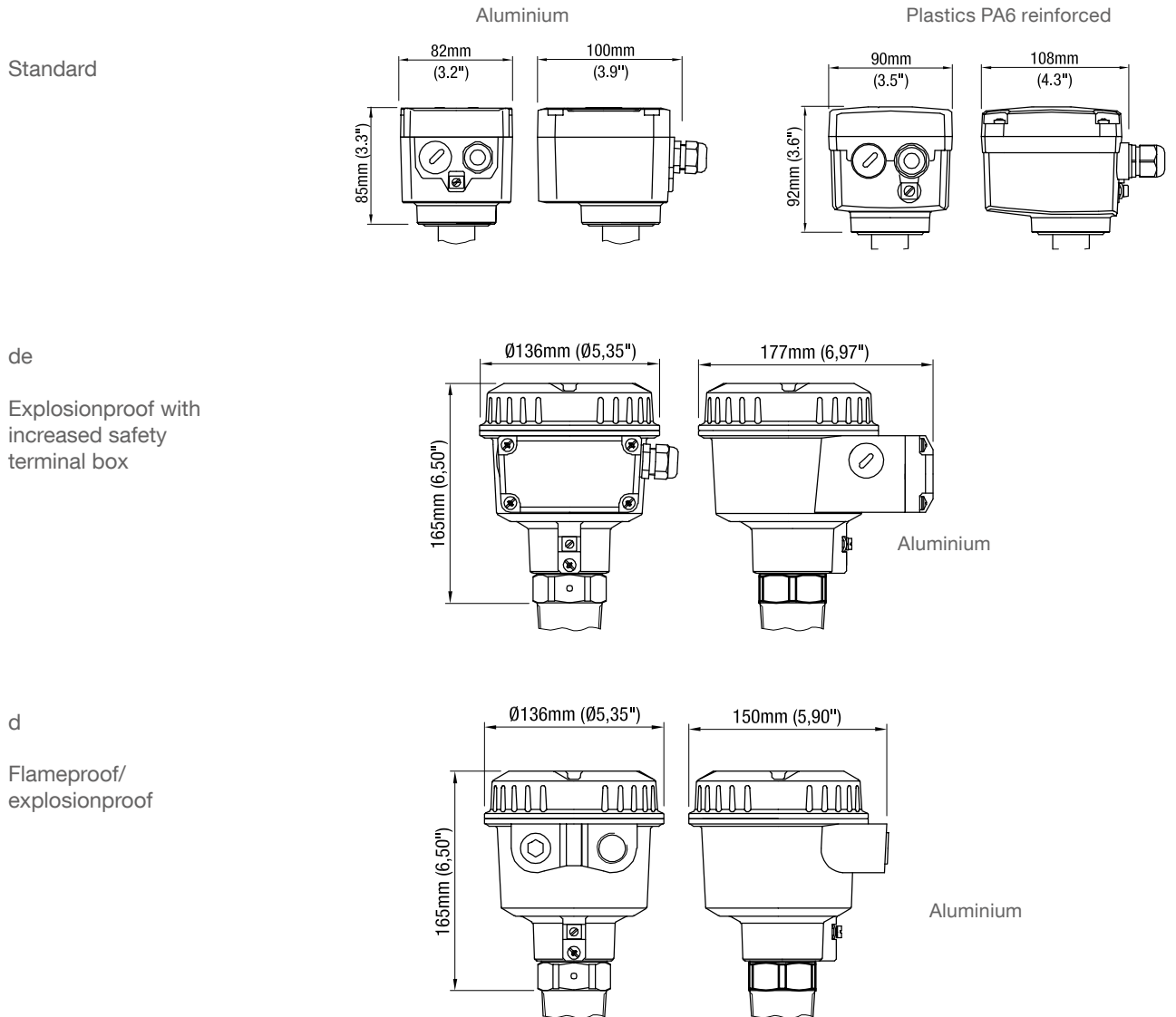

Remote version

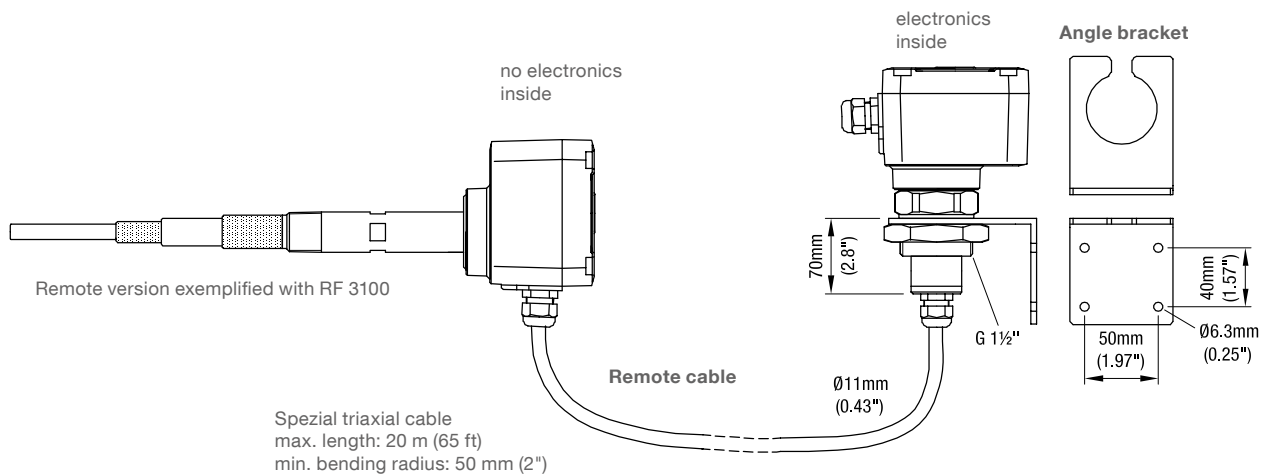

Technical data - Dimensions

Probes

RF 3100 Standard version

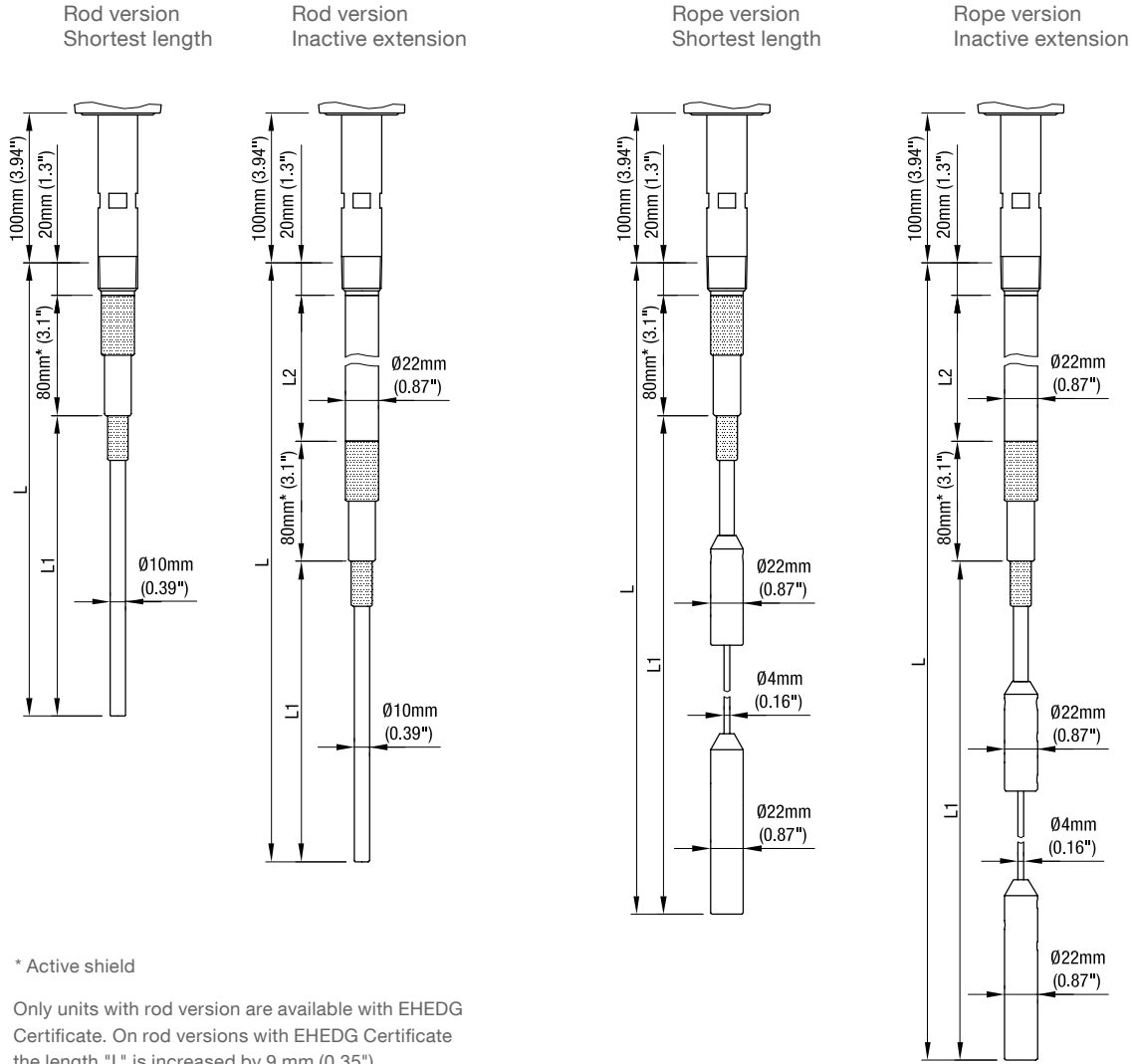

Process connections:

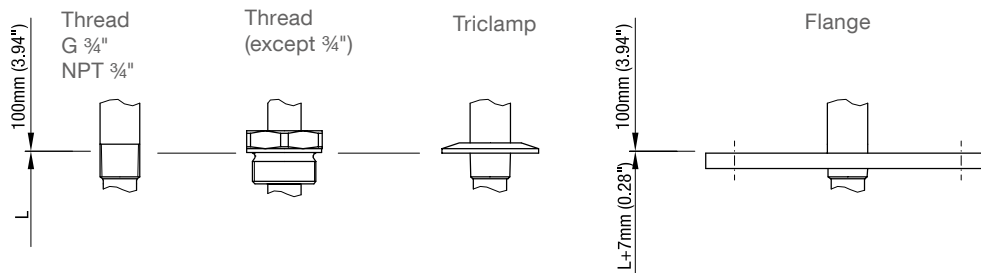

Technical data - Dimensions

RF 3200 Heavy Duty version

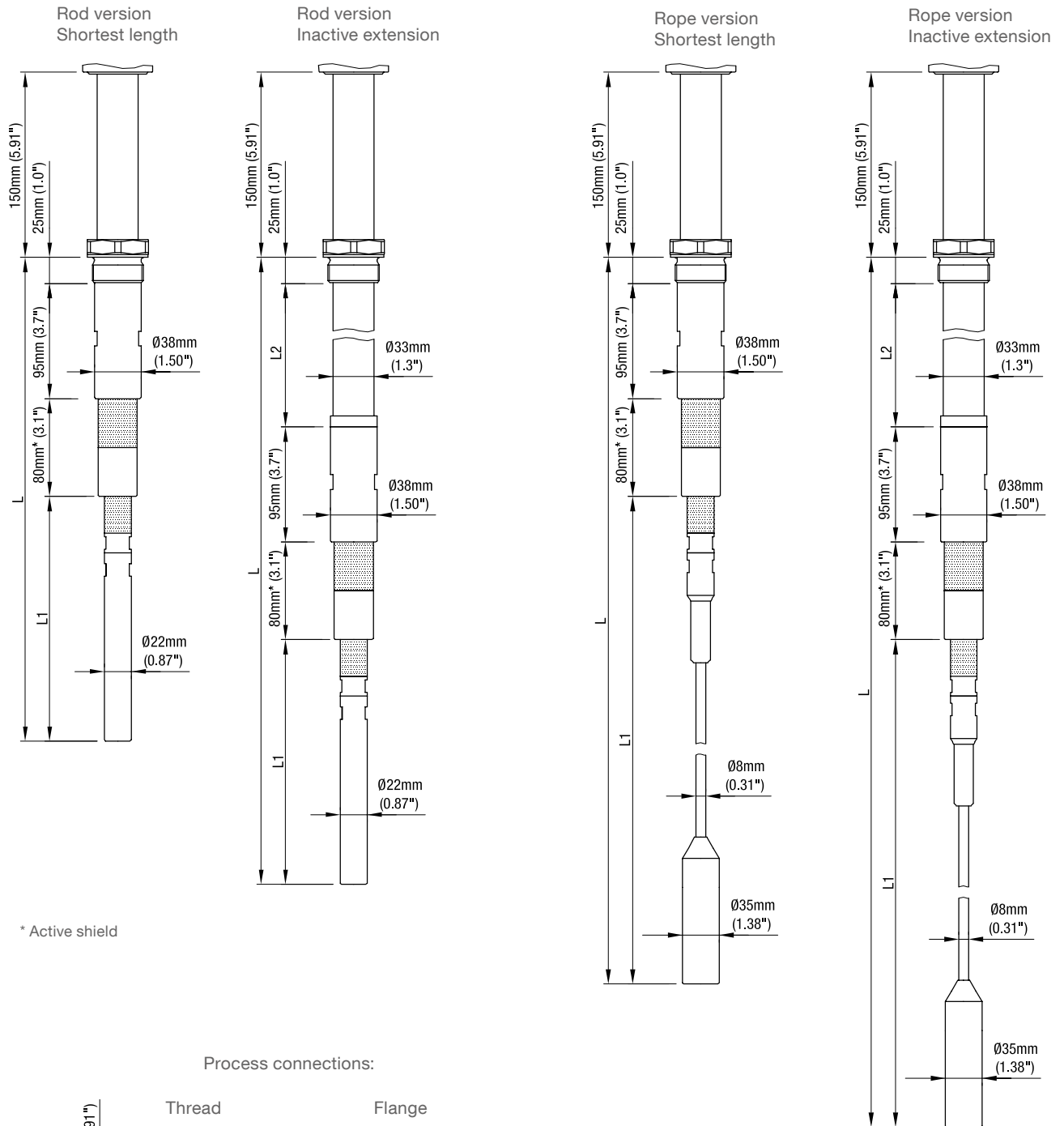

Technical data - Dimensions

RF 3000 High temperature version

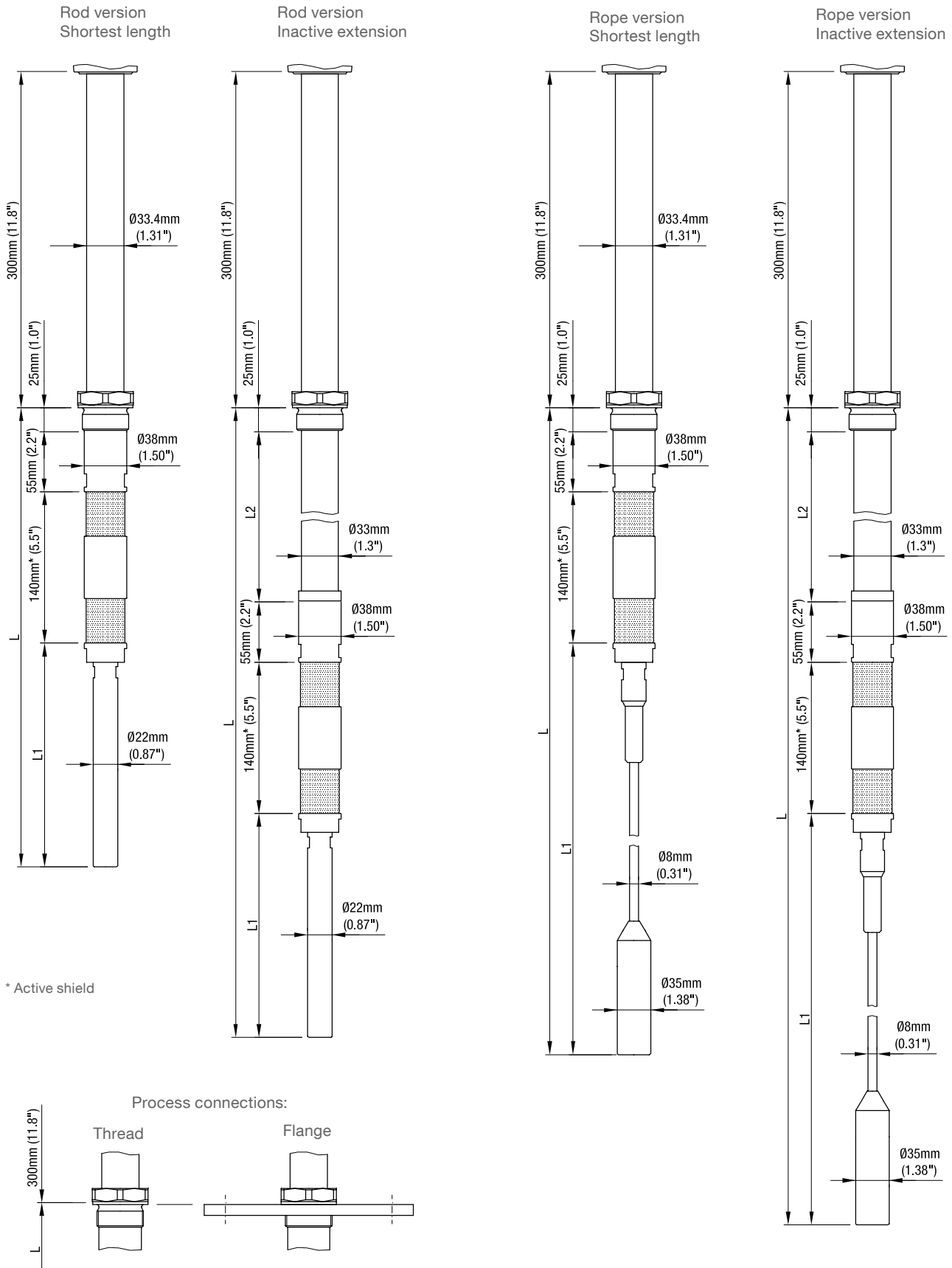

Technical data - Electrical data

Electrical data

Connection terminals	0.14 - 2.5 mm ² (AWG 26 - 14)
Cable entry	M20 x 1.5 screwed cable gland NPT ½" conduit connection NPT ¾" conduit connection Clamping range (diameter) of the factory provided cable glands: M20 x 1.5: 6 .. 12 mm (0.24 .. 0.47")
Signal delay	Sensor uncovered -> covered or covered -> uncovered or covered <-> uncovered: adjustable ca. 0.5 to 60 sec
Safety operation (FSL,FSH)	Switchable for minimum or maximum safety
Operation frequency	ca. 100 kHz
Overvoltage category	II
Pollution degree	2 (inside housing)

Electronics

Universal voltage Relay DPDT

Power supply	21 .. 230 V 50 - 60 Hz or DC ±10%* *incl. ±10% of EN 61010
Max. ripple of power supply	7 V _{ss} at DC supply
Installed load	max. 1.5 VA or 1.5 W
Signal output	Floating relay DPDT AC max. 250 V, 8 A non inductive DC max. 30 V, 5 A non inductive
Display	4 digit LCD Display of actual measured capacitance, signal output state and self diagnostics Min. operating temperature: -30°C (-22°F)
Indicating light	Status by 3 colour built-in LED (according to NE44): Power on, signal output, failure/ maintenance
Data storage	Nonvolatile EPROM for Menu settings and calibration data
Isolation	Power supply to signal output: 2,225 Vrms Signal output to signal output: 2,225 Vrms
Protection class	I

Technical data - Mechanical Data

Mechanical data

Housing	Aluminium, powder coated RAL 5010 gentian blue Optional: Plastics PA6 reinforced Seal between housing and lid: NBR Seal between housing and process connection: NBR Nameplate: polyester film
Degree of protection	IP67 (EN 60529), NEMA Type 4X
Process connection/ probes	<p>RF 3100: Total length L: 200 ... 2 500mm (7.9 ... 98.4") for rod version 450 ... 20 000mm (17.7 ... 787") for rope version Material: Stainless steel 1.4301 (304)/ 1.4305 (303) or 1.4404 (316L)/ 1.4401(316) for rope Probe isolation PPS reinforced Probe gaskets FKM or FFKM Coating of probe/rope (optional) PFA Thread: G ¾", 1", 1¼", 1½" DIN 228, M30 x 1.5, M32 x 1.5, NPT ¾", 1", 1¼", 1½" tapered ANSI B 1.20.1 Triclamp: 1" (DN25), 1½" (DN40), 2" (DN50) ISO 2852</p> <p>RF 3200: Total length L: 300 ... 2 500mm (11.8 ... 98.4") for rod version 550 ... 20 000mm (21.7 ... 787") for rope version Material: Stainless steel 1.4301 (304)/ 1.4305 (303) or 1.4404 (316L)/ 1.4401(316) for rope Probe isolation PPS reinforced Probe gaskets FKM or FFKM Thread: G 1¼", 1½" DIN 228, NPT 1¼", 1½" tapered ANSI B 1.20.1</p> <p>RF 3300: Total length L: 320 ... 2 500mm (12.6 ... 98.4") for rod version 570 ... 20 000mm (22.4 ... 787") for rope version Material: Stainless steel 1.4301 (304)/ 1.4305 (303) or 1.4404 (316L)/ 1.4401(316) for rope Probe isolation ceramic Probe gaskets graphite Thread: G 1¼", 1½" DIN 228, NPT 1¼", 1½" tapered ANSI B 1.20.1</p> <p>Flanges according to selection 1.4541 (321) or 1.4404 (316L) All material food grade</p>
Sound level	max. 40 dBA

Overall weight (ca.)

	Standard housing	de-housing	d-housing		
	Basic weight*			Active probe length: L1**	Inactive length: L2**
RF 3100 rod version	1.7 kg (3.7 lbs)	2.7 kg (6.0 lbs)	3.0 kg (6.6 lbs)	+0.62 kg/m (1.37 lbs/ 39.3")	+1.2 kg/m (2.65 lbs/ 39.3")
RF 3100 rope version	2.3 kg (5.1 lbs)	3.3 kg (7.3 lbs)	3.6 kg (8.0 lbs)	+0.06 kg/m (0.13 lbs/ 39.3")	+1.2 kg/m (2.65 lbs/ 39.3")
RF 3200 rod version	2.8 kg (6.2 lbs)	3.8 kg (8.4 lbs)	4.1 kg (9.0 lbs)	+3.0 kg/m (6.61 lbs/ 39.3")	+3.26 kg/m (7.19 lbs/ 39.3")
RF 3200 rope version	4.0 kg (8.8 lbs)	5.0 kg (11 lbs)	5.3 kg (12 lbs)	+0.26 kg/m (0.57 lbs/ 39.3")	+3.26 kg/m (7.19 lbs/ 39.3")
RF 3300 rod version	3.6 kg (8.0 lbs)	4.6 kg (10 lbs)	4.9 kg (11 lbs)	+3.0 kg/m (6.61 lbs/ 39.3")	+3.26 kg/m (7.19 lbs/ 39.3")
RF 3300 rope version	4.8 kg (11 lbs)	5.8 kg (13 lbs)	6.1 kg (13 lbs)	+0.26 kg/m (0.57 lbs/ 39.3")	+3.26 kg/m (7.19 lbs/ 39.3")

Total weight = Basic weight + active probe length L1 + inactive length L2
 All weights with 1¼" NPT process connection and without flanges
 * Rode version with shortest length L1=100 mm (3.9"), rope version without rope
 **Refer to dimension drawings on page 6 - 8

Technical data - Operating conditions

Operating conditions

Ambient temp. (housing)	-40°C .. +70°C (-40 .. +158°F)	Standard housing. Plastics housing without Ex approvals
	-20°C .. +70°C (-4 .. +158°F)	Plastics housing with Ex approvals
	-40°C .. +60°C (-40 .. +140°F)	de- and d-housing

Process temperature	RF 3100/ 3200:	-40°C .. +240°C (-40 .. +464°F)
	RF 3300:	-40°C .. +500°C (-40 .. +932°F), versions with Ex-approvals: +445°C (+833°F)

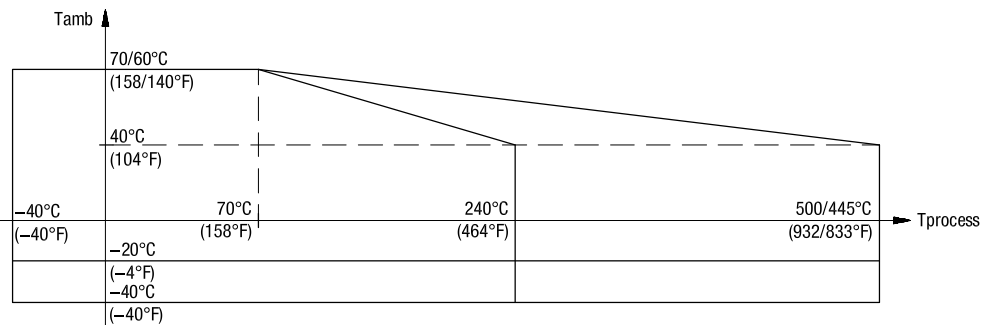

For versions with Ex-approvals: see remarks on page 42.

Ventilation	Ventilation is not required
Max. range/ max sensitivity	3 .. 100 pF/ 0.5 pF 3 .. 400 pF/ 2 pF
Spark protection	Robust build in protection against static discharge of the bulk material.
Features of bulk material	Min. DK depending on selected probe length L1 and probe diameter. See tables on page 25 and 32.

Max. mechanical load

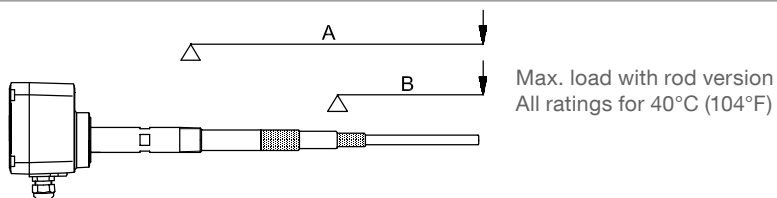

RF 3100	Rod version:	A: 125 Nm	B: 20 Nm
	Rope version:	4 kN tensile load	
RF 3200	Rod version:	A: 525 Nm	B: 90 Nm
	Rope version:	40 kN tensile load	
RF 3300	Rod version:	A: 525 Nm	B: 20 Nm
	Rope version:	10 kN tensile load	

Process pressure

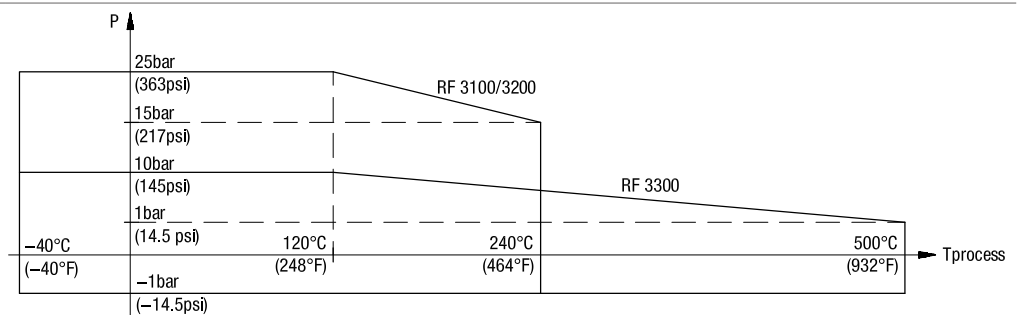

The max. process pressure may be reduced with use of flanges. Observe flange standards for pressure rating and pressure derating with higher temperature.

For versions with Ex-approvals: Further see remarks on page 41.

Technical data - Operating conditions

Vibration	1.5 (m/s ²)/ Hz according to EN 60068-2-64
Relative Humidity	0 - 100%, suitable for outdoor use
Altitude	max. 2,000 m (6,562 ft)
Expected product lifetime	Following parameters have a negative influence on the expected product lifetime: High ambient- and process temperature, corrosive environment, high vibration, high flow rate of abrasive bulk material passing the sensor element.

Transport and Storage

Transport	<p>Observe the instructions as stated on the transport packaging, otherwise the products may get damaged.</p> <p>Transport temperature: -40 .. +80°C (-40 .. +176°F) Transport humidity: 20 .. 85%</p> <p>Transport incoming inspections must be carried out to check for possible transport damage.</p>
Storage	<p>Products must be stored at a dry and clean place. They must be protected from influence of corrosive environment, vibration and exposure to direct sunlight.</p> <p>Storage temperature: -40 .. +80°C (-40 .. +176°F) Storage humidity: 20 .. 85%</p>

Approvals / Options

Approvals

General Purpose * (Ordinary Locations)	CE FM/ FMc TR-CU	EN 61010-1			
Hazardous Locations*	ATEX (1)	Dust explosion	Protection by enclosure	II 1/2D Ex ia/tb IIIC T! Da/Db	
		Gas explosion	Flameproof Flameproof/ increased safety	II 2G Ex db ia IIC T! Gb II 2G Ex db eb ia IIC T! Gb	
	IEC-Ex (1)	Dust explosion	Protection by enclosure	Ex ia/tb IIIC T! Da/Db	
		Gas explosion	Flameproof Flameproof/ increased safety	Ex db ia IIC T! Gb Ex db eb ia IIC T! Gb	
	FM	Dust explosion	Protection by enclosure	DIP-IS Cl. II, III Div.1 Gr. E,F,G	
		Gas explosion	Flameproof	XP-IS Cl. I Div.1 Gr. B,C,D Cl. I Zone 1 Gr. IIB+H2	
	TR-CU	Dust explosion	Protection by enclosure	Ex ia/tb IIIC T! Da/Db X	
		Gas explosion	Flameproof Flameproof/ increased safety	1Ex d ia IIC T! Gb X 1Ex de ia IIC T! Gb X	
	(1) Markings are stated for compact version. Markings for remote version see selection list Detailed allocation of types and electronic modules to approvals: see selection list.				
	EMC	EN 61326 - A1			
	Hygiene*	EHEDG (Type ED)			
	Food grade material	According to directive 1935/2004/EC			
Pressure Equipment Directive (2014/68/EU)	The units are not subject to this directive, because they are classified as „pressure-keeping equipment“ and do not have a pressurized housing (see Art.1, clause 2.1.4). The units are designed and manufactured in accordance to the Pressure Equipment Directive. The unit is NOT intended for use as a “equipment part with safety function (Art.1, clause 2.1.3). If the units should be used as „equipment part with safety function, please contact the manufacturer.				

* depending on selected version in the selection list.

Options

Various options are available, see pricelist for more details:

Remote version • Probe and electronic housing separated (cable length up to 20 m (65 ft))

Electronics • Preselected sensitivity (factory setting of switching sensitivity)

Probes • Coating rod version
 • Coating rope version (rope)
 • Extension kits (rigid or flexible rod extension, rope extension)

Mounting • Sliding sleeve (flexible height adjustment of the probe)
 Material 1.4305 (303) / 1.4541 (321) or 1.4404 (316L)
 Max 25bar (363psi), 240°C (464°F)
 • EHEDG approval (Type ED)
 • Mounting sets: Screws, washers, sealings for fixing the unit on a flange.

Housing • Housing material plastics PA6
 • Weather protection cover (PE, weathering and temperature stable)
 • Cable entry (metric or NPT with different size)
 • Signal lamp (LED, indiation of signal output state from outside)
 • Plugs (valve connector, M12 plug, Harting)

Mounting

! General Safety Instructions

Process pressure	Improper installation may result in loss of process pressure. Seal the process thread with Teflon tape in case of process pressure A plastic sealing must be used to tighten the flange.
Fastening of the threaded process connection	Mounting torque for the thread may not exceed 80 Nm. Use a fitting open-end wrench. Do not fasten by turning the housing. Sliding sleeve: Tighten both straining screws M8 with 20 Nm to obtain resistance against pressure.
Precaution for later dismantling/ Service	Grease the screws of the lid if corrosive atmosphere is present (e.g. close to sea)
Direction of the cable glands	When the unit is mounted from the side, ensure, that the cable glands faces downwards and are closed to avoid water penetration into the housing. The housing can be rotated against the process connection after mounting.
Chemical resistance against the medium	Materials of construction are chosen based on their chemical compatibility (or inertness) for general purposes. For exposure to specific environments, check with chemical compatibility charts before installing.
Temperature range	The range of the ambient and process temperature of the device must be observed.
Mechanical load	The rated values must not be exceeded.
EHEDG/ Food grade material	The materials are available for the use under normal and predictable applications (according to directive 1935/2004 Art.3). Other conditions can influence the safety.

! Additional Safety Instructions for Hazardous Locations

Installation regulations	For devices to use in hazardous locations the respectively valid installation regulations must be observed.
Sparks	The installation has to be done in a way mechanical friction or impact can not cause sparks between the aluminium enclosure and steel.
Weather protection cover	The weather protection cover is approved for Zone 2, 22 and Div.2

Mounting

EHEDG Approval

Metal-metal sealing:

- The support must be plane and without any gap. No teflon tape (or similar) is allowed to be in between.
- Fixing torque 100 Nm

The quality of the welding with the container wall must be according to the respective regulations (e.g. gaps, transitions, surface finish).

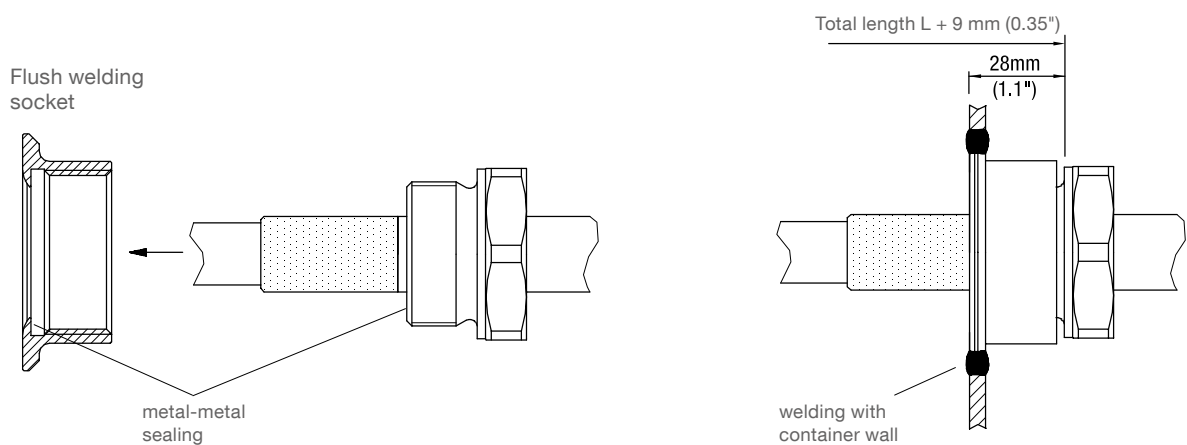

Dimension of flush welding socket (for optional on site manufacturing):

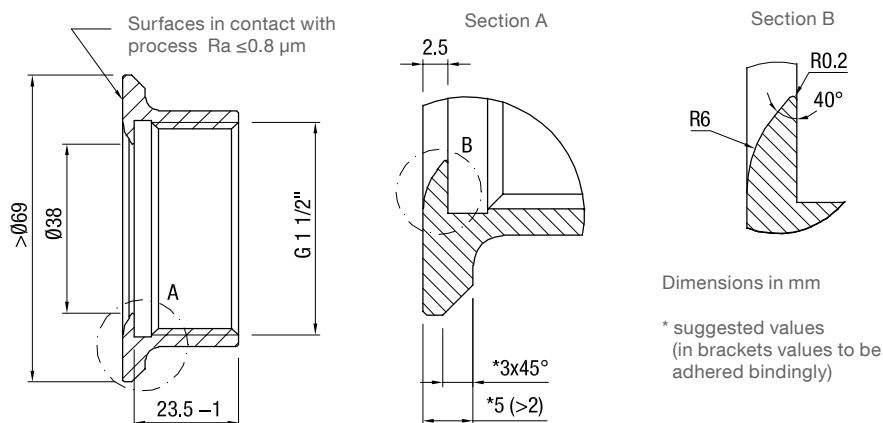

Mounting

Mounting: Rod version

Observe distance to active probe

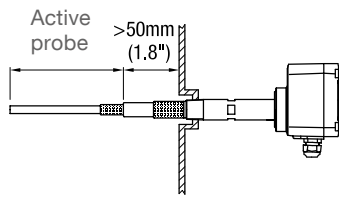

CORRECT
Horizontal mounting

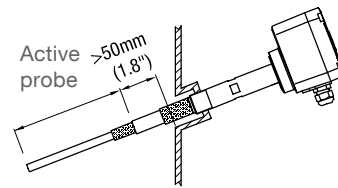

CORRECT
Oblique mounting
Helps remaining material to fall off

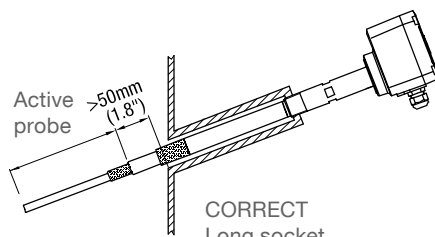

CORRECT
Long socket.
Use of inactive length.

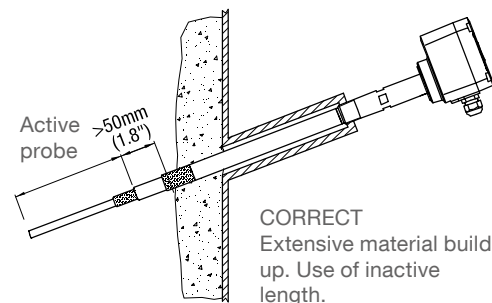

CORRECT
Extensive material build up. Use of inactive length.

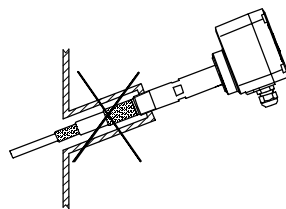

WRONG
Active probe inside socket.

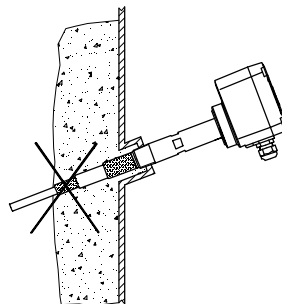

WRONG
Active probe inside material build up.

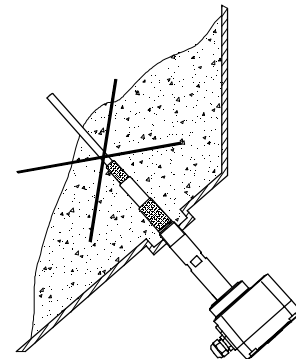

WRONG:
Active probe inside intersection between cylindrical and conical part of the silo (material may stay when silo is empty)

Mounting

Observe min. distance between two sensors, to metal silo wall and to protective angle.

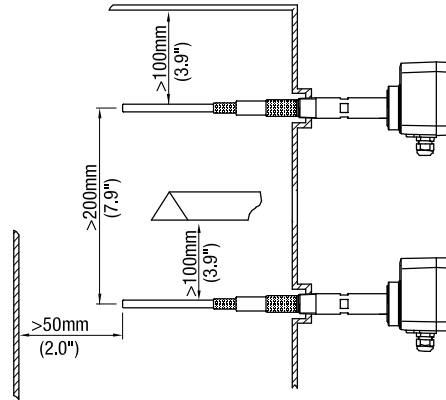

Grounding reference with non metal silos

The inner or outer PE terminal must be connected to reach a grounding reference.

Further mounting requirements

- Observe distance to material flow (filling).
- Protective angle recommended depending on mechanical load and abrasion of the material.

Switching point

With proper calibration the signal output switches when the active probe is covered by material.

Mounting

Mounting: Rope version

Observe distance to active probe

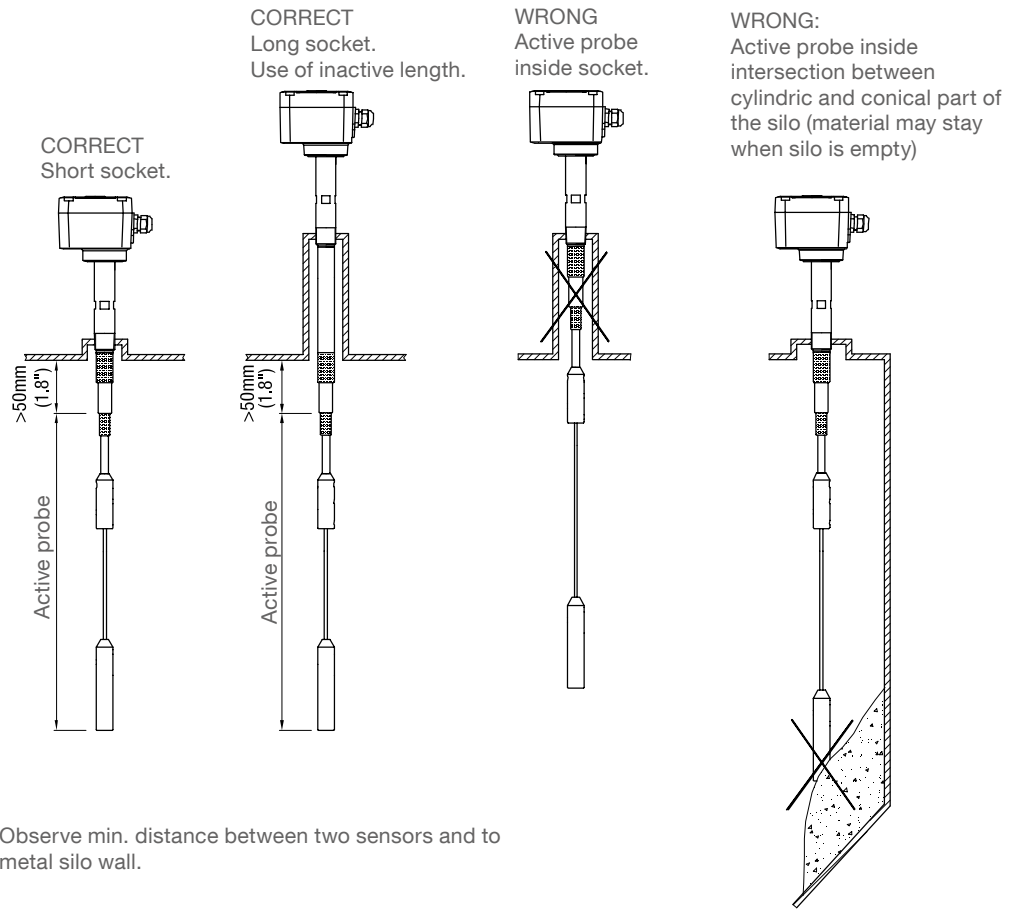

Observe min. distance between two sensors and to metal silo wall.

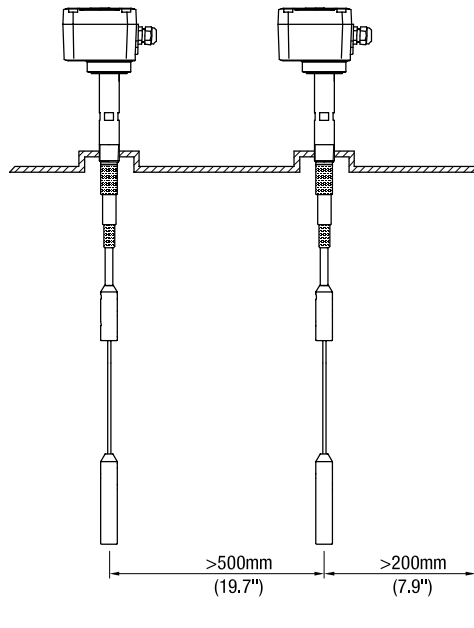

Grounding reference with non metal silos

The inner or outer PE terminal must be connected to reach a grounding reference.

Further mounting requirements

- Observe distance to material flow (filling).
- Empty detector: Do not mount above the center of the silo outlet due to high traction force.
- Unit must be installed vertical.

Electrical installation

! General Safety Instructions

Handling	In the case of inexpert handling or handling malpractice the electric safety of the device cannot be guaranteed.
Protective earthing	Before any electrical installation, the terminal inside the housing must be connected to the protective earth.
Installation regulations	The local regulations or VDE 0100 (Regulations of German Electro technical Engineers) must be observed. With use of 24 V supply voltage, an approved power supply with reinforced insulation to mains is required.
Fuse	Use a fuse as stated in the connection diagrams.
RCCB protection	In the case of a defect, the distribution voltage must automatically be cut off by a RCCB protection switch so as to protect the user of the device from indirect contact with dangerous electric tensions.
Power supply switch	A Power-supply-disconnecting switch must be provided and marked near the device.
Wiring diagram	The electrical connections have to be made according to the wiring diagram.
Supply voltage	Compare the supply voltage applied with the specifications given on the electronic and name plate before switching the device on.
Cable gland/ closing element	<p>The screwed cable gland and closing element must have following specifications:</p> <p>Ingress protection IP67, temperature range from -40°C to +80°C, UL or VDE certified (depending on the country where the unit is installed), pull relief.</p> <p>Make sure that the screwed cable gland safely seals the cable and that it is tight (danger of water intrusion).</p> <p>Cable glands that are not used have to be locked with a closing element.</p> <p>A strain relief must be provided for the field wiring cables, when the device is installed with the factory provided cable glands.</p>
Conduit system	In case of using a conduit system (with NPT thread) instead of a cable gland the regulations of the country where the unit is installed must be observed. The conduit must have a tapered thread either NPT 1/2" or NPT 3/4" in accordance with the unit and ANSI B 1.20.1. Not used inlets must be closed tight with a metal closing element.
Field wiring cables	<ul style="list-style-type: none"> • The diameter has to match to the clamping range of the used cable gland. • The cross section has to match with the clamping range of the connection terminals and consider the max. current. • All field wirings must have insulation suitable for at least 250 V AC. • The temperature rating must be at least 90°C (194°F). • If higher immunity interferences as specified in the stated EMC standards are present (see chapter approval), a shielded cable is required, otherwise an unshielded instrumentation cable is satisfactory.
Connecting the terminals	Make sure that max. 8 mm (0.31") of the pigtailed are bared (danger of contact with live parts).
Guiding the cables in the terminal box	Cut the field wiring cables to appropriate length to fit properly into the terminal box.
Remote housing	The remote cable must be installed separated from power supply lines to avoid immunity interferences. The min. bending radius of 50 mm (2") must be observed.

Electrical installation

Relay protection	Provide protection for relay contacts to protect the device against spikes with inductive loads.
Protection against static charging	The housing of the unit must be grounded in any case to avoid static charging of the unit on applications with pneumatic conveying and non-metallic containers .
Opening the lid	Before opening the lid take care, that the unit is clean and no water or dirt can enter into the housing.

! Additional Safety Instructions for Hazardous Locations

External equipotential bonding terminal

Connect with equipotential bonding of the plant

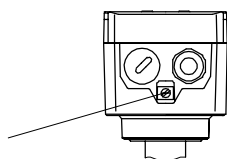

Field wiring	A pull relief must be provided for the field wiring cables, when the device is installed with the factory provided cable glands.
---------------------	--

Field wiring terminals for "de" housing	Fixing torque : 0.5 - 0.6 Nm Remove wire isolation: 9 mm (0.35")
--	---

Cable glands and conduit system for ATEX/ IEC-Ex/ TR-CU (Dust and Gas Hazardous Locations)	<p>Installation according to the regulations of the country, where the product is installed.</p> <p>Not used entries have to be closed with blanking elements certified for this purpose.</p> <p>Where available the factory provided parts must be used.</p> <p>A strain relief must be provided for the field wiring cables, when the device is installed with the factory provided cable glands.</p> <p>If other than the factory provided parts are used, following must be ensured: The parts must have an approval adequate to the approval of the level sensor (certificate and type of protection). The approved temperature range must be from the min. ambient temperature of the level sensor to the max. ambient temperature of the level sensor increased by 10 Kelvin. The parts must be mounted according to the instructions of the supplier.</p>
--	--

Conduit system for FM (Dust and Gas Hazardous Locations)	<p>General requirements: In addition the regulations of the country must be observed. The used flameproof seals and blanking elements must have an adequate type approval and a temperature range of at least -40°C (-40°F) to +80°C (176°F). In addition they shall be suitable for the conditions and correctly installed. Where available the provided original parts of the manufacturer must be used.</p> <p>Installation of a flameproof enclosure "d" with a conduit system: In a conduit system single electric conductors are installed in a certified pipe system. This pipe system is in a flameproof construction as well. The flameproof enclosure "d" and the pipe system needs to be sealed from each other by a certified flameproof seal. Conduit entries of a flameproof enclosure "d" shall have installed the flameproof seal within 18 inches from the enclosure wall. Not used entries have to be closed with adequate blanking elements of a certified flameproof type Cl.1 Div.1 A.</p>
--	---

Opening the lid	<p>Units with Dust Explosion approval: Before opening the lid take care, that no dust deposits or whirlings and no hazardous atmosphere is present.</p> <p>Units with flameproof GasExplosion approval (d-housing): To prevent ignition of hazardous atmospheres, do not remove the lid (cover) while circuits are alive.</p>
------------------------	---

Electrical installation

Connection

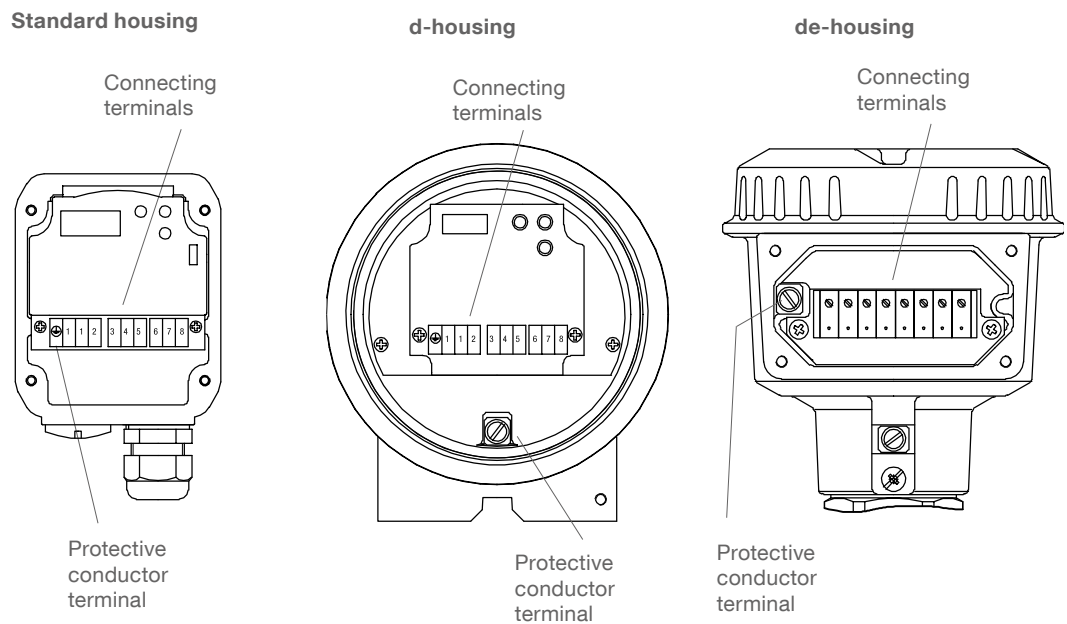

Universal voltage Relay DPDT

Power supply:

21 .. 230 V 50/ 60 Hz or DC $\pm 10\%$
 1.5 VA or 1.5 W

Fuse on power supply:
 max. 10 A, 250 V, HBC, fast or slow

Signal output:

Floating relay DPDT
 AC max. 250 V, 8 A, non inductive
 DC max. 30 V, 5 A, non inductive

Fuse on signal output:
 max. 10 A, 250 V, HBC, fast or slow

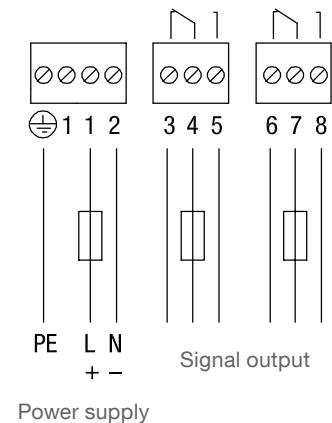

Quickstart

Quickstart

User interface

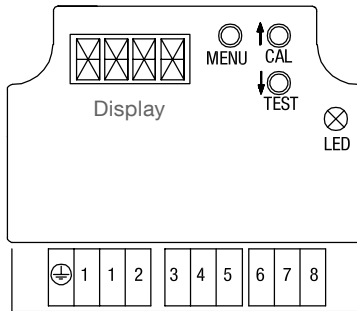

LEDs:
 Green = relay activated
 Yellow = relay idle
 Red = maintenance (blinking), error (on)

Power up calibration at first time operation

Behaviour after first time power up (factory setting).

If unit is switched OFF and then again ON, this calibration will NOT be repeated.

<p>1. Ensure material level is well below the probe.</p>	<p>Ensure that the unit is properly mounted and the material level is well below the probe, since the unit will calibrate to an uncovered probe.</p>	
<p>2. Power up calibration</p>	<p>After first time power up, the unit will automatically calibrate. During calibration (ca. 45 seconds) display states "CAL", red LED is blinking. After calibration display states the actual measured capacitance followed by "u" for "Signal output states uncovered".</p> <p>If other statements on the display are present, see Trouble shooting, page 37.</p>	
<p>3. Checking Quickstart settings</p>	<p>If required to change the factory settings for Fail Safe High/ Low, Signal output delay or Sensitivity, use Quickstart menu (see page 24).</p>	
<p>Unit is ready to work</p>		

Measurement mode

The unit states the actual measured capacitance and the state of the signal output

Display	LED	Explanation
XXX u XXX c	green/ yellow*	<p>Actual measured capacitance in pF. Actual signal output: states uncovered probe "u" or covered probe "c"</p> <p>Resolution is 0.1 pF (<100 pF) or 0.5pF (>100 pF). If values are >100 pF, a dot behind the number means 0.5 pF (e.g. 100. means 100.5 pF)</p> <p>Note: If the actual measured capacitance is higher than electronic can measure (>400pF with sensitivity setting ≥2 pF or >100 pF with sensitivity setting ≤1pF), the unit will state "400c" or "100c". The measurement is valid, since the actual capacitance is well above the calibrated switchpoint. Signal output states covered probe "c" in any case.</p>

* Green or yellow depending on FSH/ FSL setting, see page 24.

If other statements on the display are present, see Trouble shooting, page 37.

Quickstart

Quickstart menu

Note: Red LED is blinking during Menu setting



- When the unit is in Measurement mode, press MENU button for 3 sec to enter in Quickstart menu.
 Note: If "Code" is displayed, a Lock Code is required. Set the code number with the arrow buttons and confirm with the Menu button. Then press again the Menu button for 3 sec to enter in Quickstart menu.
- Press for 3 sec to return to Measurement mode.
- Press for <1 sec to store setted value and jump to next menu item.
- If no button is pressed within ca 5min, the unit returns to the measurement mode (timeout). All changed menu settings will be stored.



- Arrow buttons increase/ decrease the value to be setted

Display	Explanation	Menu item
A. FSH * FSL	Fail Safe High Fail Safe Low	Signal output, Fail safe setting
B. ALL * C-U U-C	Covered probe <-> Uncovered probe Covered probe -> Uncovered probe Uncovered probe -> Covered probe	Signal output, Delay direction
C. 0,5 * 2 5 to 60	seconds	Signal output, Delay time Adjustable in steps (increment is 5 seconds)
D. 0,5 1 2 ** 4 10 15 25 35	pF	Sensitivity Required capacitance increase between uncovered probe (after calibration) and switch to output "covered probe". Change presetted value only if required by the application, see calibration guide on page 25. Note: Menu item D is not valid and will not be shown on the display, if Manual calibration (Menu item G) is set to ON.

* Factory setting

** Standard Factory setting is 2 pF. Optional other setting is present (depending on order)

FSH/ FSL Setting

FSH: Set as full detector. Power failure or line break is stated as "full" signal (protection against overcharging).

FSL: Set as empty detector. Power failure or line break is stated as "empty" signal (protection against dry running).

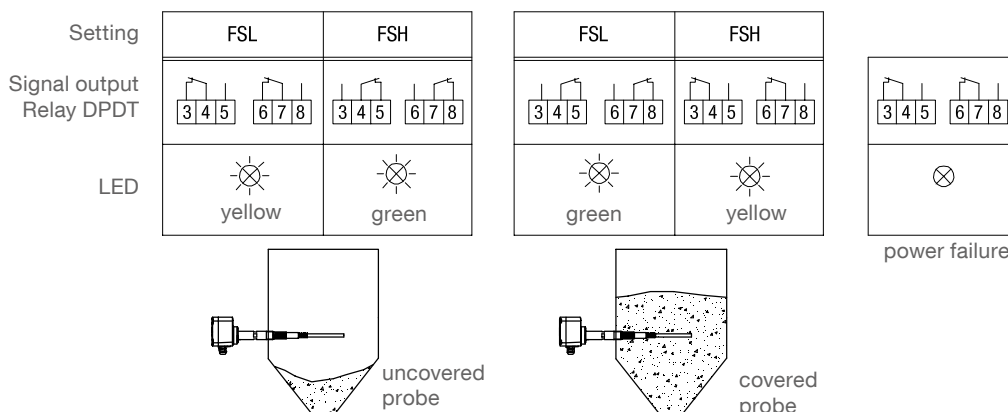

Quickstart

Push button calibration - Calibration guide

Push button calibration needs to be done, if "Power up calibration at first time operation" was not successful or unit was changed to another location or a significant change of DK was present after changing of material.

- **Calibration with uncovered probe only:**

This method is most simple and thus recommended to be done if ever possible.

A proper selection of the active probe length is necessary to reach a satisfactory change of capacitance between uncovered and covered probe (see recommendations in the external selection list). If these recommendations are observed, the standard sensitivity of 2 pF can be used in most cases.

If a too small change of capacitance between uncovered and covered probe is present, a higher sensitivity can be selected (1 pF or 0.5 pF). This is not possible if remote version with remote cable length >10 m (33 ft) is installed outdoors (temperature drift).

For higher change of capacitance and evt. excessive buildup, the sensitivity can be reduced (4 pF or more).

Calibration procedure see page 26.

- **Calibration with uncovered and covered probe:**

This method is most safe, since it sets the switchpoint in the middle between uncovered and covered probe capacitance. This ensures the max. switching distance to both uncovered and covered probe capacitance and thus ensures the max. tolerance against e.g. material buildup. The method is required for lower DK values which give a lower change of capacitance. The DK value of the material is not required to be known.

Calibration procedure see page 27.

Quickstart

Push button calibration - Calibration procedure - Uncovered probe only

Explanation of calibration procedure:

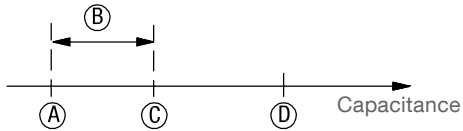

- A Capacitance Uncovered probe
- B Sensitivity
- C Switchpoint
- D Capacitance Covered probe

<p>1. Ensure material level is well below the probe.</p>	<p>Ensure that the unit is properly mounted and the material level is well below the probe, since the unit will calibrate to an uncovered probe.</p>	
<p>2. Set Sensitivity</p>	<p>Only if required (see page 25) Set the Sensitivity in the Quickstart Menu, item "D", see page 24.</p>	
<p>3. Press CAL button for 3 seconds</p>	<p>During calibration the display states "CAL", the red LED is blinking. Wait until calibration is finished (ca. 10 seconds). Then display states the actual measured capacitance followed by "u" for "Probe uncovered".</p> <p>Note: If "Code" is displayed, a Lock Code is required. Set the code number with the arrow buttons and confirm with the Menu button. Then press again the CAL button for 3sec to start calibration.</p>	
<p>Unit is ready to work.</p>	<p>If other statements on the display are present, see Troubleshooting, page 37.</p>	

Quickstart

Push button calibration - Calibration procedure - Uncovered and covered probe

Explanation of calibration procedure:



<p>1. Ensure material level is well below the probe.</p>	<p>Ensure that the unit is properly mounted and the material level is well below the probe, since the unit will calibrate to an uncovered probe.</p>																																									
<p>2. Press CAL button for 3 seconds</p>	<p>Display states "CAL", the red LED is blinking. Wait until calibration is finished (ca. 10 seconds). Then display states the actual measured capacitance followed by "u" for "Probe uncovered".</p> <p>Note: If "Code" is displayed, a Lock Code is required. Set the code number with the arrow buttons and confirm with the Menu button. Then press again the CAL button for 3 sec to start calibration.</p> <p>If other statements on the display are present, see Trouble shooting, page 37.</p>																																									
<p>3. Note actual measured capacitance (uncovered probe)</p>	<p>Note the actual measured capacitance as stated in the display for uncovered probe.</p>																																									
<p>4. Note actual measured capacitance (covered probe)</p>	<p>For vertical mounting (rope version) the material level shall cover the probe weight by 10 - 20 cm (4 - 8").</p> <p>Note the actual measured capacitance as stated in the display for covered probe.</p>																																									
<p>5. Set Sensitivity</p>	<p>Calculate the capacitance difference between uncovered and covered probe. Set sensitivity as follows (Quickstart Menu item "D"):</p> <table border="1" style="width: 100%; border-collapse: collapse;"> <thead> <tr> <th colspan="2" style="text-align: left;">Horizontal mounting</th> <th colspan="2" style="text-align: left;">Vertical mounting (rope version)</th> </tr> <tr> <th style="text-align: left;">Capacitance difference uncovered-covered</th> <th style="text-align: left;">Sensitivity*</th> <th style="text-align: left;">Capacitance difference uncovered-covered</th> <th style="text-align: left;">Sensitivity**</th> </tr> </thead> <tbody> <tr> <td>0.8 .. 1.5 pF</td> <td>0,5 pF***</td> <td>0.5 .. 1.0 pF</td> <td>0.5 pF***</td> </tr> <tr> <td>1.5 .. 3 pF</td> <td>1 pF***</td> <td>1.0 .. 2 pF</td> <td>1 pF***</td> </tr> <tr> <td>3 .. 6 pF</td> <td>2 pF</td> <td>2 .. 4 pF</td> <td>2 pF</td> </tr> <tr> <td>6 .. 15 pF</td> <td>4 pF</td> <td>4 .. 10 pF</td> <td>4 pF</td> </tr> <tr> <td>15 .. 23 pF</td> <td>10 pF</td> <td>10 .. 15 pF</td> <td>10 pF</td> </tr> <tr> <td>23 .. 38 pF</td> <td>15 pF</td> <td>15 .. 25 pF</td> <td>15 pF</td> </tr> <tr> <td>38 .. 53 pF</td> <td>25 pF</td> <td>25 .. 35 pF</td> <td>25 pF</td> </tr> <tr> <td>> 53 pF</td> <td>35 pF</td> <td>> 35 pF</td> <td>35 pF</td> </tr> </tbody> </table> <p>* The difference uncovered to covered should be well above the setted sensitivity (ca. >50%). ** The difference uncovered to covered does not need to be above the setted sensitivity, since with raising material the capacitance will increase and thus lead to a save switching. *** Not possible with remote version with remote cable length >10 m (33 ft) and outdoor installation (temperature drift).</p> <p>Note: If different materials needs to be measured in the same bin without recalibration, the Sensitivity must be set for the material with the lowest DK.</p>	Horizontal mounting		Vertical mounting (rope version)		Capacitance difference uncovered-covered	Sensitivity*	Capacitance difference uncovered-covered	Sensitivity**	0.8 .. 1.5 pF	0,5 pF***	0.5 .. 1.0 pF	0.5 pF***	1.5 .. 3 pF	1 pF***	1.0 .. 2 pF	1 pF***	3 .. 6 pF	2 pF	2 .. 4 pF	2 pF	6 .. 15 pF	4 pF	4 .. 10 pF	4 pF	15 .. 23 pF	10 pF	10 .. 15 pF	10 pF	23 .. 38 pF	15 pF	15 .. 25 pF	15 pF	38 .. 53 pF	25 pF	25 .. 35 pF	25 pF	> 53 pF	35 pF	> 35 pF	35 pF	
Horizontal mounting		Vertical mounting (rope version)																																								
Capacitance difference uncovered-covered	Sensitivity*	Capacitance difference uncovered-covered	Sensitivity**																																							
0.8 .. 1.5 pF	0,5 pF***	0.5 .. 1.0 pF	0.5 pF***																																							
1.5 .. 3 pF	1 pF***	1.0 .. 2 pF	1 pF***																																							
3 .. 6 pF	2 pF	2 .. 4 pF	2 pF																																							
6 .. 15 pF	4 pF	4 .. 10 pF	4 pF																																							
15 .. 23 pF	10 pF	10 .. 15 pF	10 pF																																							
23 .. 38 pF	15 pF	15 .. 25 pF	15 pF																																							
38 .. 53 pF	25 pF	25 .. 35 pF	25 pF																																							
> 53 pF	35 pF	> 35 pF	35 pF																																							
<p>Unit is ready to work.</p>																																										

Quickstart

Calibration - general items

Reset to "Power up calibration at first time operation"

It may be required, that an already calibrated unit shall do a new Power up calibration when the supply voltage is switched on (e.g. if the unit shall be installed in a different bin or shall be pesetted and afterwards send to the end user).

To do this, press the CAL button for 3 seconds to initiate a Push button calibration. While the calibration is running ("CAL" is displayed), switch off the supply voltage. Since the calibration was startet, but not sucessfully finished, it will automatically start again when power is back.

Note: Only the calibration is affected, the settings in the menus will not change.

Data storage of last valid calibration values

If power supply is switched off, the last valid calibration values are stored and are still valid when power is switched on again.

Manual Function Test (proof test)

General items

The unit allows to test the internal electronics and the external connected signal evaluation.

Test procedure



In Measurement mode:
 Start the test by pressing the TEST button for 3 seconds.

Note: If "Code" is displayed, a Lock Code is required. Set the code number with the arrow buttons and confirm with the Menu button. Then press again the TEST button for 3 sec to start test procedure.

Test runs for ca. 20 seconds. Display states "TST". Signal output and yellow status LED will change state for ca. 10 sec and then return to former state (relais on-off-on or off-on-off).

If test result is not okay, the display states "ERR", red LED is on, Relais is set to de-energized. Electronic is defect and must be changed.

Advanced programming

Advanced programming - Advanced menu

Advanced menu

Note: Red LED is blinking during Menu setting



- When the unit is in Measurement mode, press MENU button for 10 sec to enter in Advanced menu (keep pressed, ignore when unit goes after 3 sec to Quickstart Menu and A.FSx is displayed).
 Note: If "Code" is displayed, a Lock Code is required. Set the code number with the arrow buttons and confirm with the Menu button. Then press again the Menu button for 10 sec to enter in Advanced menu.
- Press for 3 sec to return to Measurement mode.
- Press for <1 sec to store setted value and jump to next menu item.
- If no button is pressed within ca 5min, the unit returns to the measurement mode (timeout). All changed menu settings will be stored.



- Arrow buttons increase/ decrease the value to be setted

Display	Explanation	Menu item
Auto recalibration		
F.	OFF * ON	<p>Auto recalibration to uncovered probe. If may be required to do comissioning in an already filled silo (covered probe). With covered probe a proper calibration is not possible. A solution can be to cause the unit to do a auto calibration when the silo becomes empty (uncovered probe).</p> <p>To do this, set Auto recalibration to "ON" and do a push button calibration with a covered probe (press the CAL button for 3 seconds).</p> <p>The unit will recalibrate to uncovered probe automatically after 2 minutes, if the measured capacitance becomes 50% of the setted sensitivity (Menu item D) lower than the calibrated capacitance. During calibration "CAL" is displayed.</p> <p>Do not set to "ON" if excessive material build up is present, since this build up may decrease the measured capacitance and causes a wrong calibration.</p> <p>Note: Menu item F is not valid and will not be shown on the display, if Manual calibration (Menu item G) is set to "ON".</p>
Manual calibration		
The unit allows Manual calibration similar to conventional potentiometer calibration, but using a comfortable display and menu. Procedure for Manual calibration see page 32 to 34.		
G.	OFF * ON	<p>Manual calibration ON/OFF If set to ON:</p> <ul style="list-style-type: none"> - Menu items H, K, L appear. - Menu items D (Sensitivity in Quicksart Menu) and F (Auto recalibration) are no more valid and will be hidden. - Push button calibration is no more possible (if CAL button is pressed, the display states G.ON")
H.	LO * HI	<p>Sensitivity range Low sensitivity range allows to detect a capacitance change of ≥ 2 pF High sensitivity range allows to detect a capacitance change of ≥ 0.5 pF See also calibration guide on page 32</p>

* Factory setting

Continuation next page

Advanced programming - Advanced menu

K.	xxx	pF	<p>Switchpoint covered -> uncovered</p> <p>Explanation of switchpoints:</p>  <p>A Capacitance uncovered probe C Switchpoint covered -> uncovered (Menu item K) D Hysteresis (Menu item L) E Switchpoint uncovered -> covered F Capacitance covered probe</p> <p>Factory setting is lowest pF value (3 pF).</p> <p>Resolution is 0.1 pF (<100 pF) or 0.5 pF (>100 pF). If values are >100 pF, a dot behind the number means 0.5 pF (e.g. 100. means 100.5 pF)</p>
L.	xxx	pF	<p>Hysteresis</p> <p>Hysteresis can be adjusted if unstable capacitance is present with covered probe (e.g. moving liquid surface with vertical mounting) to avoid nervous switching of signal output.</p> <p>Minimum value (= factory setting) is 0.5/ 0.2 pF (for Low/ High sensitivity) . Maximum value is limited by the max. measurable capacitance.</p> <p>Resolution see "Switchpoint covered -> uncovered".</p>
Diagnostics			
M.	ON * OFF		<p>Auto Function Test</p> <p>The unit allows to permanently auto test the internal electronics. The test runs in the background and does not influence the functionality of the measurement.</p> <p>If a failure is detected, the display states "ERR", the red LED is on and the relais is set to de-energized. Electronic is defect and must be changed.</p>
N.	xxx	pF	<p>Actual calibrated Switchpoint covered -> uncovered</p> <p>If "OR" or "UR" is stated, there is no valid calibration (see Troubleshooting page 37)</p>
P.	xxx	pF	<p>Actual calibrated Switchpoint uncovered -> covered</p> <p>If "OR" or "UR" is stated, there is no valid calibration (see Troubleshooting page 37)</p>
Q.	xxx	°C	<p>Min. stored electronics temperature</p>
R.	xxx	°C	<p>Max. stored electronics temperature</p>
S.	xxx		<p>Software version</p>
T.	xxx		<p>Service values</p> <p>The values are manufacturer internal and not be stated in detail with this user manual</p>
Divers			
V.	xxx		<p>Lock code</p> <p>The Lock code can be set to protect entering in any Menu or doing a Push Button Calibration or a Manual Function Test. Any number from 1 to 999 can be set. With setting "000" the Lock Code is not active (factory setting). If a Lock code was set and forgotten, call manufacturer to get the release code.</p>
W.	NO* YES		<p>Factory reset</p> <p>First all parameters will be reset to factory settings (as stated with an "*)". Second the unit will automatically start a new calibration.</p>

* Factory setting

Advanced programming - Manual calibration

Manual calibration - Calibration guide

Manual calibration is recommended for special purposes.

The numbers in the table below are applicable for most applications. Some critical applications (e.g. excessive buildup, special mounting) may be considered different.

A proper selection of the active probe length is necessary in any case to reach a satisfactory change of capacitance between uncovered and covered probe, see recommendations in the selection list (pricelist). The table below is based on a proper active probe length.

- Calibration with uncovered probe only:

This method is more easy to realise than calibration with uncovered and covered probe and thus recommended to be done if ever possible. It is applicable for higher DK values which give a higher change of capacitance between uncovered and covered probe. The DK value of the material is required to be known to be able to set the sensitivity range and the increase to switchpoint. See external list for dielectric constant (DK) of different materials.

- Calibration with uncovered and covered probe:

This method is most safe, since it sets the switchpoint in the middle between uncovered and covered probe. This ensures the max. distance to both uncovered and covered probe and thus ensures the max. tolerance against e.g. material buildup. It is required for lower DK values which give a lower change of capacitance. The DK value of the material is roughly required to be known to be able to set the sensitivity range. See external list for dielectric constant (DK) of different materials.

Manual Calibration - Calibration guide

DK	Sensitivity range	Calibration: Uncovered probe only	Increase to Switchpoint	Calibration: Uncovered and covered probe
<1.5	-	-	-	-
1.5 .. 1.6	High	-	-	A
1.7 .. 1.9	High	B	+1 pF*	C
2.0 .. 2.9	Low	B	+2 pF	C
3.0 .. 4.9	Low	B	+4 pF	C
5.0 .. 10	Low	B	+10 pF	C
>10	Low	B	+15 pF	C
		Calibration prodedure see page 33		Calibration prodedure see page 34

A = Required

B = Recommended (most simple calibration method)

C = Possible as an alternative

- = Not applicable

* Not possible with remote version with remote cable length >10 m (33 ft) and outdoor installation (temperature drift).

Advanced programming - Manual calibration

Manual calibration - Calibration procedure - Uncovered probe only

Note: Manual calibration must be set to ON (Advanced menu, item G)

Explanation of calibration procedure:

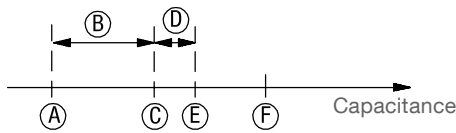

- A Capacitance uncovered probe
- B Increase to switchpoint
- C Switchpoint covered -> uncovered
- D Hysteresis
- E Switchpoint uncovered -> covered
- F Capacitance covered probe

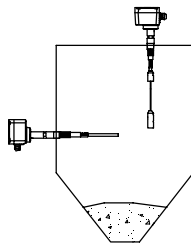
<p>1. Ensure material level is well below the probe.</p>	<p>Ensure that the unit is properly mounted and the material level is well below the probe, since the unit will calibrate to an uncovered probe.</p> 
<p>2. Set Sensitivity range</p>	<p>Check for the required Sensitivity range (low or high) depending on the material to be measured, use calibration guide on page 32.</p> <p>Set the Sensitivity range in the Advanced Menu item "H", see page 30.</p>
<p>3. Find capacitance of uncovered probe</p>	<p>Goto Advanced Menu item "K". Start with lowest capacitance (factory setting is ca. 3 pF). Unit states covered. Increase the displayed capacitance, until the output just changes from covered to uncovered.</p> <p>Notes:</p> <ul style="list-style-type: none"> - The signal output delay should be set to 0.5 sec. - In measurement mode the actual measured capacitance is displayed. This gives an indication, at which capacitance the output will change from covered to uncovered. - If the output has once changed to uncovered and shall change back to covered, the value must be decreased by the setted Hysteresis (Menu item "L"). <p>If the actual measured capacitance is close to the limits of what the electronic can measure (400 pF with sensitivity setting "Low" or 100 pF with sensitivity setting "High"), see Trouble shooting, page 37.</p>
<p>4. Set switchpoint covered -> uncovered</p>	<p>In Advanced Menu item "K". Set the Switchpoint covered -> uncovered as follows: Capacitance of uncovered probe (see step 3 above) + Increase to switchpoint (see table on page 32)</p>
<p>5. Hysteresis</p>	<p>Advanced Menu item "L". Factory setting is normally not required to be changed.</p>
<p>Unit is ready to work.</p>	<p>Return to measurement mode.</p>

Advanced programming - Manual calibration

Manual calibration - Calibration procedure - Uncovered and covered probe

Note: Manual calibration must be set to ON (Advanced menu, item K)

Explanation of calibration procedure:

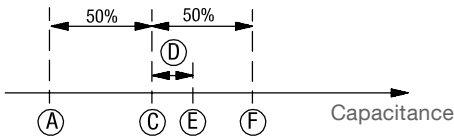

- A Capacitance uncovered probe
- C Switchpoint covered -> uncovered
- D Hysteresis
- E Switchpoint uncovered -> covered
- F Capacitance covered probe

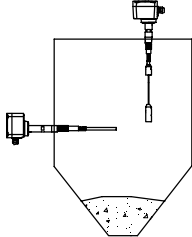
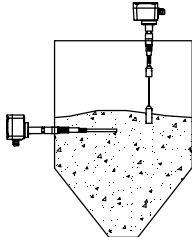
<p>1. Set Sensitivity range</p>	<p>Check for the required Sensitivity range (low or high) depending on the material to be measured, use calibration guide on page 32.</p> <p>Set the Sensitivity range in the Advanced Menu item "H", see page 30.</p>
<p>2. Note actual measured capacitance (uncovered probe)</p>	<p>Ensure that the unit is properly mounted and the material level is well below the probe.</p> <p>In Measurement mode: Note the actual measured capacitance as stated in the display.</p> <p>If the actual measured capacitance is close to the limits of what the electronic can measure (400pF with sensitivity setting "Low" or 100pF with sensitivity setting "High"), see Trouble shooting, page 37.</p> 
<p>3. Note actual measured capacitance (covered probe)</p>	<p>Ensure that the material level is above the probe.</p> <p>For vertical mounting (rope version): The material level shall cover the probe weight by 10 - 20 cm (4 - 8").</p> <p>In Measurement mode: Note the actual measured capacitance as stated in the display.</p> 
<p>4. Set Switchpoint covered -> uncovered</p>	<p>Goto Advanced Menu item "K". Set to the middle between capacitance of uncovered and covered probe as follows:</p> $\text{Switchpoint covered -> uncovered} = \text{uncovered}^{(1)} + 0.5 \times (\text{covered}^{(2)} - \text{uncovered}^{(1)})$ <p>(¹) Capacitance uncovered probe (see step 2 above) (²) Capacitance covered probe (see step 3 above)</p> <p>With Low sensitivity range (Advanced Menu item "H"): If the difference between uncovered and covered probe is smaller than 4 pF, set either to High sensitivity or use a more sensitive probe (longer active probe). For rope version only a setting to High sensitivity range is possible.</p> <p>With High sensitivity range (Advanced Menu item "H"): If the difference between uncovered and covered probe is smaller than 1 pF, use a more sensitive probe (longer active probe). For rope version call factory.</p> <p>* For remote version with remote cable length >10 m (33 ft) and outdoor installation the difference between uncovered and covered probe must be at least 4 pF (temperature drift).</p>
<p>5. Hysteresis</p>	<p>Advanced Menu item "L". Factory setting is normally not required to be changed.</p>
<p>Unit is ready to work.</p>	<p>Return to measurement mode.</p>

Probe modifications



- Modifications on units with explosion approvals (Hazardous Locations) are not permitted. Consult factory.
- Modifications may change the technical data (mechanical stability).

CAUTION:

- Never do modifications on other than the active part of the probe. This will destroy the probe.
- Electronics must be removed in any case (see page 39).
- Take care not to overheat the plastic parts of the probe during welding or cutting.
- Use same material as the probe when welding to the probe.

- Recalibration is required after any modification on the probe.

Probe	Modification	Note
Rod version	Shortening	This will reduce the sensitivity (critical for material with low DK)
	Extending	Consider high mechanical load (rod bending) from bulk material
Rope version	Shortening	Proper fixing of the rope weight after rope cutting is required
	Extending	Consider high mechanical load (traction) from bulk material and reduced stability of a rope, if it is not made from one piece

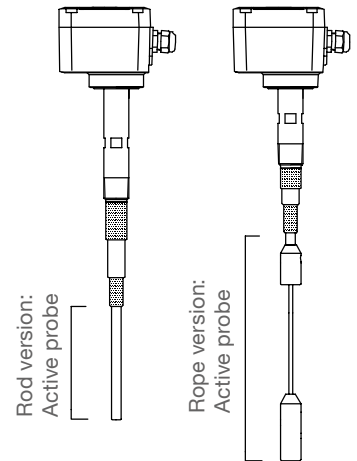

Assembly - Remote version / FM Control drawing

- All cable glands used for the remote cable must be closed tightly to reach ingress protection.
- The cable glands must be protected against mechanical damage.
- Original remote cable from the supplier must be used.

For Hazardous Locations:
 Remote cable has intrinsically safe circuit.
 Substitution of components may impair intrinsic safety.

Assembly instruction:

Probe side:

Connect remote cable.
 Obtain right connecting sequence.
 The inner conductor and both shield conductors of the remote cable must not touch other metal parts. The delivered isolation hoses must be assembled according to the delivered instruction.

Electronic side:

1. Feed remote cable through the cable gland at the tube.
2. Connect remote cable to the plug.
 See notes above.
3. Check wiring electrically:
 No short circuit must be present between terminal 10 and 11, 10 and 12, 11 and 12.
4. Connect plug and mating plug.
5. Screw the tube into the threaded bush. While doing this, move the remote cable downwards. Take care, that the plug is not getting loose. While screwing, the cable gland must be open to avoid, that the wires are being twisted.
 Note: Inside the threaded bush is a seal ring which seals the tube to the threaded bush.
6. Tighten the cable gland on the tube.
7. Fasten the two fixing screws.

Versions (for FM):

Standard housing:
 Model RF 3*00 * N with option pos.12 x
 Cl. II, III Div.1 Gr. E,F,G

"d"-housing:
 Model RF 3*00 * U with option pos.12 x
 XP-IS Cl. I,II,III Div.1 Gr. B-G and
 Cl. I Zone 1 Gr. IIB+H2

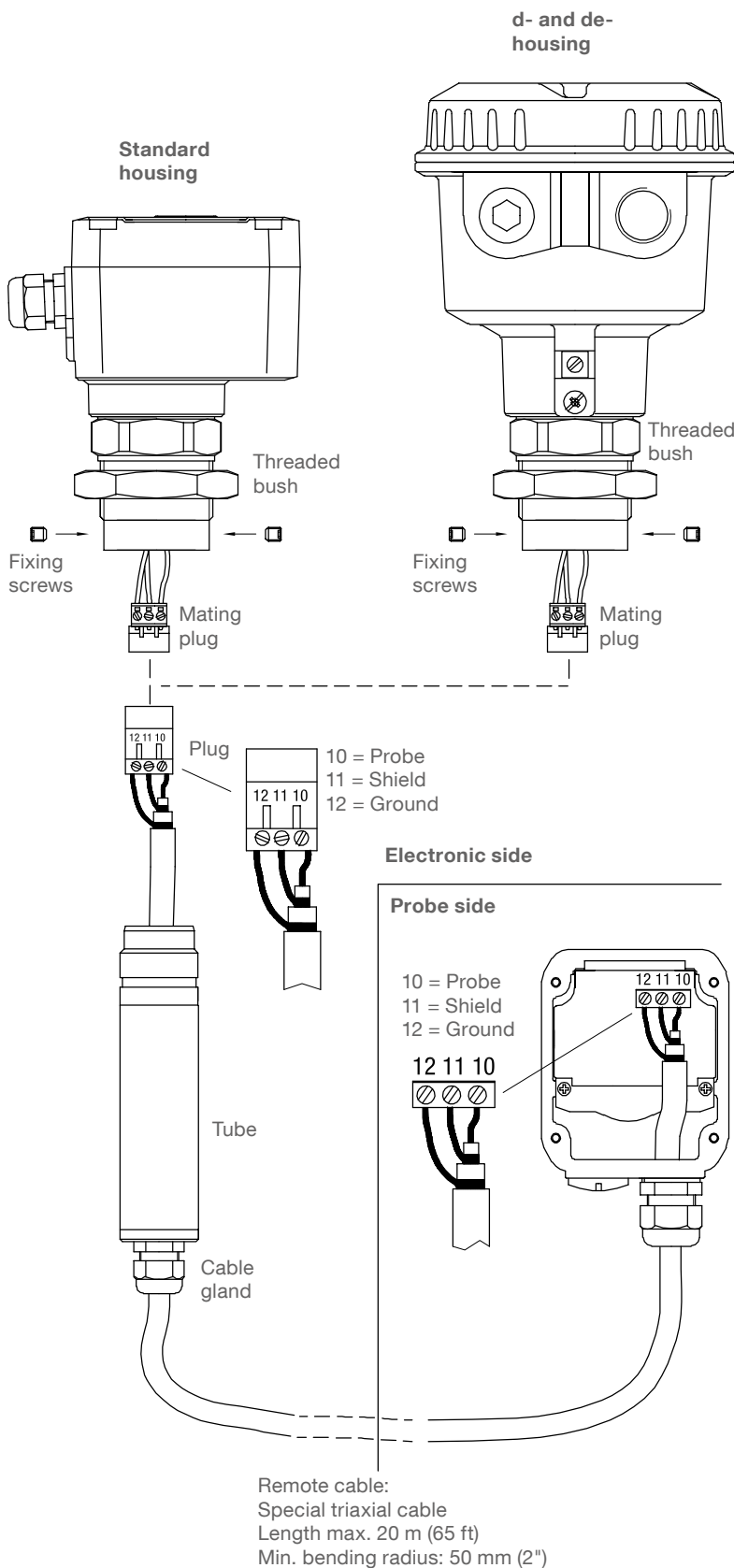

Troubleshooting

Maintenance and error messages

Display	LED	Explanation	Possible Reason/ Solution
In Measurement Mode:			
UR	red blinking	Under Range. Actual measured capacitance is lower than 3 pF.	<ul style="list-style-type: none"> Probe is defect or defect/ incorrect probe wiring. The signal output relay will be de-energized.
OR	rot blinkend	Over Range. After changing the Sensitivity from ≥ 2 pF to ≤ 1 pF.	<ul style="list-style-type: none"> Actual calibrated capacitance is higher than 100 pF and can not be measured with Sensitivity setting ≤ 1 pF. Change to Sensitivity 2 pF if DK of the material is high enough or recalibrate.
ERR	red on	Auto or Manual Function Test error.	<ul style="list-style-type: none"> Electronic is defect. Change of electronic. The signal output relay will be de-energized.

During Power up calibration at first time operation or during Push button calibration:

OR	red blinking	Over Range. Actual measured capacitance is higher than 400 pF (Sensitivity set to ≥ 2 pF) or 100 pF (Sensitivity set to ≤ 1 pF). Calibration not possible.	<ul style="list-style-type: none"> A long rope version in an empty silo may exceed 100 pF capacitance. Change to Sensitivity 2 pF if DK of the material is high enough. Probe may be covered with material. Ensure that probe is uncovered. Check if Probe is defect or defect/ incorrect probe wiring.
UR	red blinking	Under Range. Actual measured capacitance is lower than 3 pF. Calibration not possible.	<ul style="list-style-type: none"> Probe is defect or defect/ incorrect probe wiring. The signal output relay will be de-energized.
G.ON	red blinking	CAL button pressed with Manual calibration setted to "ON". Push button calibration is not possible.	<ul style="list-style-type: none"> If Push button calibration is required, set Manual calibration to "OFF".

During Manual calibration (when probe is uncovered):

Close to 100 or 100	yellow/ green	With sensitivity range setting "High" Actual measured capacitance is close to or higher than 100 pF (what the electronic can measure). Calibration not possible.	<ul style="list-style-type: none"> A long rope version in an empty silo may exceed 100 pF capacitance. Change to Sensitivity range "Low" if DK of the material is high enough. Probe may be covered with material. Ensure that probe is uncovered. Check if Probe is defect or defect/ incorrect probe wiring.
Close to 400 or 400	yellow/ green	With sensitivity range setting "Low" Actual measured capacitance is close to or higher than 400 pF (what the electronic can measure). Calibration not possible.	<ul style="list-style-type: none"> Probe may be covered with material. Ensure that probe is uncovered. Check if Probe is defect or defect/ incorrect probe wiring.

Troubleshooting

General items

Situation	Behaviour of the electronic	Possible Reason	Possible Solution
Signal output states covered while material is below the probe	The actual measured capacitance (1) is more than the actual calibrated Switchpoint uncovered -> covered (2)	Unit not properly calibrated	• Recalibrate (4)
		Excessive material build up on active probe	• Increase distance to wall (longer inactive length) • Change position • Recalibrate with less sensitivity (4)
		Defect or incorrect probe wiring.	• Check probe wiring (see below)
Signal output states uncovered while material is above the probe	The actual measured capacitance (1) is less than the actual calibrated Switchpoint covered -> uncovered (3)	Calibration was done with covered probe	• Recalibrate with uncovered probe (4)
		Calibrated was done with too less sensitivity	• Recalibrate with higher sensitivity (4) • Increase active probe length and recalibrate (4)
		Defect or incorrect probe wiring.	• Check probe wiring (see below)

(1) Value can be seen in the display in Measurement mode (see page 23)

(2) Value can be seen in Advanced Menu, item P (see page 31)

(3) Value can be seen in Advanced Menu, item N (see page 31)

(4) See calibration guide, page 25 or 32

Checking probe wiring

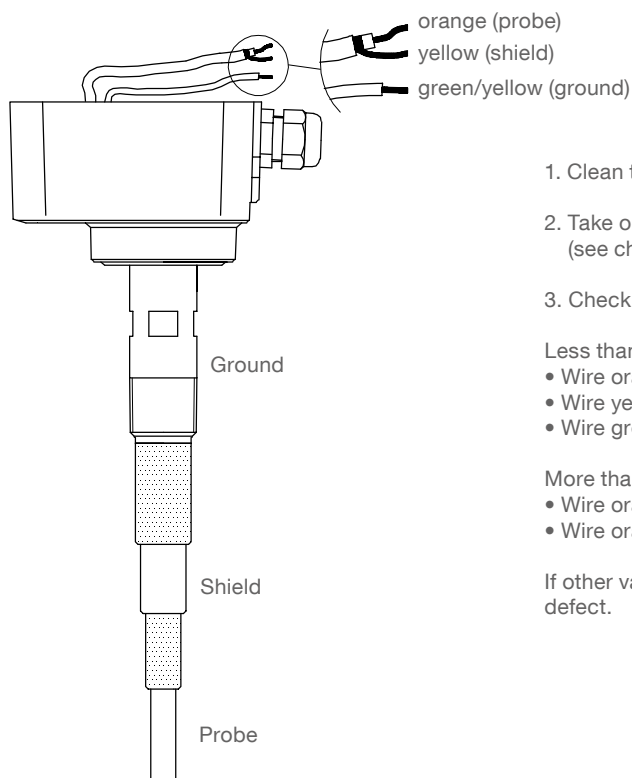

1. Clean the probe from material
2. Take out the electronic board and remove internal wires (see chapter "Maintenance")
3. Check with Multimeter as follows (see drawing):

Less than 5 Ohm must be present between:

- Wire orange and Probe
- Wire yellow and Shield
- Wire green/ yellow and Ground

More than 1 MOhm resistance must be present between:

- Wire orange and wire yellow
- Wire orange and wire green/ yellow

If other values are present, the probe or probe wiring is defect.

Maintenance

General items

Opening the lid (cover)	<p>⚠ Before opening the lid for maintenance reasons observe following items:</p> <ul style="list-style-type: none"> • Do not remove the lid while circuits are alive. • No dust deposits or whirlings are present. • No rain can enter into the housing.
Frequent check of the unit	<p>⚠ To ensure durable safety in hazardous locations and with electrical safety, following items must be checked frequently depending on the application:</p> <ul style="list-style-type: none"> • Mechanical damage or corrosion of any components (housing side and sensor side) and of the field wiring cables. • Tight sealing of the process connection, cable glands and enclosure lid. • Properly connected external PE cable (if present). • For process temperatures over 230°C the delivered sealings of the flanges and of the sliding sleeve must be checked regularly for good order and condition.
Cleaning	<p>⚠ If cleaning is required by the application, following must be observed:</p> <ul style="list-style-type: none"> • Cleaning agent must comply with the materials of the unit (chemical resistance). Mainly the lid sealing, cable gland and the surface of the unit must be considered. <p>⚠ The cleaning process must be done in a way, that:</p> <ul style="list-style-type: none"> • The cleaning agent cannot enter into the unit through the lid sealing or cable gland. • No mechanical damage of the lid sealing, cable gland or other parts can happen. <p>Units with EHEDG certification, which are used in the respective EHEDG applications, must be cleaned dry only (Type ED). Furthermore the respective regulations must be observed.</p> <p>A possible accumulation of dust on the unit does not increase the maximum surface temperature and must therefore not be removed for purposes of maintaining the surface temperature in hazardous locations.</p>
Function test	<p>A frequent function test may be required depending on the application. Execution of function test see page 29</p>
Production date	<p>The production date can be traced by the serial number on the typeplate. Please contact the manufacturer or your local distributor.</p>
Spare parts	<p>All available spare parts are stated in the selection list.</p>

Maintenance

Change of electronic board

- ! • Opening the lid (cover): see safety notes on page before
- ! • Hazardous Locations: The unit must have always an electronic board inserted and conneted to the probe. If the electronic board is not connected to the probe, the probe acts as an isolated capacitance. The risk of static charge and thus possible explosion is present.

1. Open the housing lid
2. Remove the field wiring cables
3. Remove the two fastening screws
4. Take out the electronic board, remove cable ties and internal wires
5. Mount a new electronic board in reverse sequence

CAUTION:

- Observe right sequence of internal probe wires
- Obeserve to reconnect the internal grounding wire

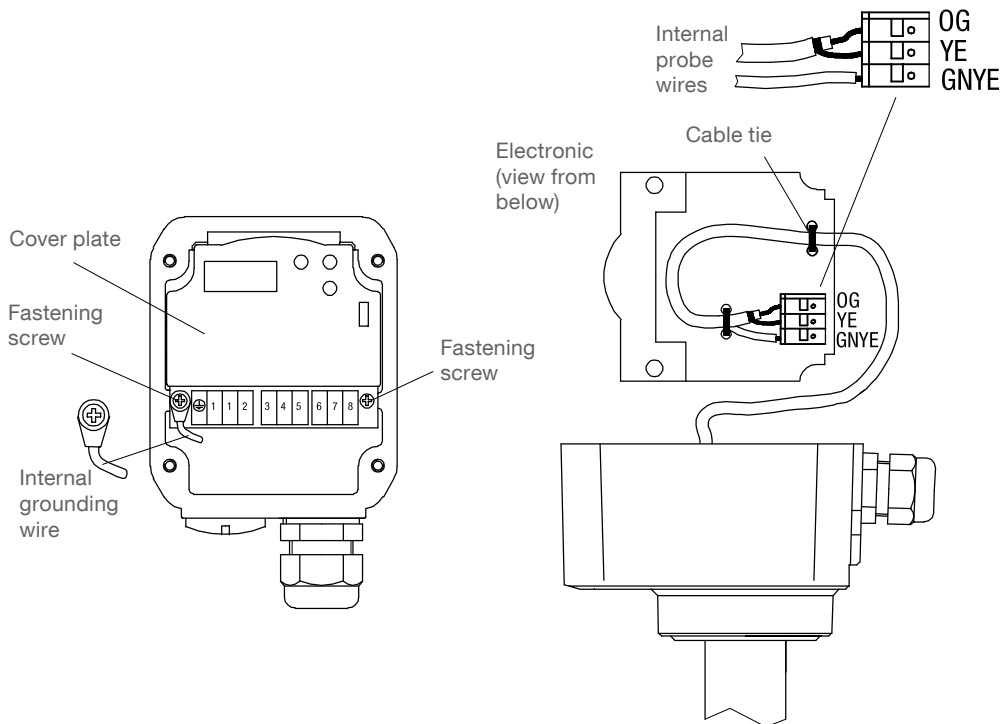

Repair of flamepath

Repair of flamepath on units with Ex d, Ex de or XP approvals is not intended.
 Please contact manufacturer.

Notes for use in Hazardous Locations

Zone classification

	usable in zone	ATEX category	IEC-Ex Equipment Protection Level (EPL)
Dust applications	20, 21, 22	1 D	Da
	21, 22	2 D	Db
	22	3 D *	Dc
Gas applications	0, 1, 2	1 G	Ga
	1, 2	2 G	Gb
	2	3 G	Gc

* in case of conductive dust additional requirements for the installation may be necessary.

General Notes

Marking

Devices with Ex approval are marked on name plate.

Process pressure



Devices with Ex Approval are approved for atmospheric pressure.
 A detailed explanation is given below for ATEX and applies analogously for other Ex approvals:
 • The scope of the ATEX directive is generally limited to atmospheric pressure, see ATEX directive 2014_34_EU Chapter 1 Art.2 (4).
 Atmospheric pressure is defined as absolute pressure 0.8bar to 1.1bar, see ATEX guideline §50 and IEC 60079-0 chapter 1 Scope.
 The technical background is that an explosive atmosphere which is compressed (overpressure) or released (underpressure) can exhibit different explosion behaviour than under atmospheric conditions. The standards for the types of protection against explosion (IEC 60079 series), on which a type approval according to the ATEX directive is based, are designed for atmospheric conditions and do not automatically cover deviating pressure conditions.
 Thus, an ATEX type approval issued in accordance with this directive only covers atmospheric pressure.
 This applies to all manufacturers.
 A deviating operating pressure can be assessed and approved by an expert for the respective application.
 Regardless of this, the design of the level indicators is suitable for a vessel overpressure / underpressure in accordance with the specified technical data.

Process and ambient temperature

The permitted temperature ranges are marked on the name plate.
 The max. permitted ambient and process temperatures (including temperature derating) stated in this manual must be observed.

Notes for use in Hazardous Locations

Permitted zones (categories) for mounting in partition wall

	With Standard housing	With d- and de-housing	
EPL (IEC-Ex)	Db	Gb	Db
Category (ATEX)	2D	2G	2D
Zone	21	1	21

	Da	Gb	Da
EPL (IEC-Ex)	Da	Gb	Da
Category (ATEX)	1D	2G	1D
Zone	20	1	20

Standard housing d-housing de-housing

Standard housing d-housing de-housing

Rod Rod, remote version

Rope Rope, remote version

RF 3100
RF 3200
RF 3300

Max. Surface Temperature and Temperature Class

The temperature marking on the name plate refers to the instruction manual.

On the following tables the relevant temperature ratings are shown.

The maximum surface temperature (resp. temperature class) is the warmest temperature of the unit which could occur during malfunction (according to Ex-definition).

Max. ambient temperature	Max. process-temperature	Max. Surface temperature	Temperature class
70°C (158°F) (3) 60°C (140°F) (4)	≤120°C (248°F)	120°C (248°F)	T4
	≤130°C (266°F)	(1)	T4
	≤195°C (383°F)	(1)	T3
	≤240°C (464°F)	(1)	T2
	≤295°C (563°F) (2)	(1)	T2
	≤445°C (833°F) (2)	(1)	T1

- (1) The max. surface temperature is the same as the max. process temperature
- (2) Only with RF 3300
- (3) With standard housing
- (4) With d- and de-housing

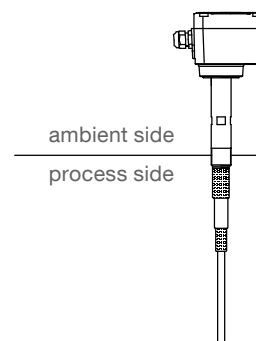

Disposal

The product consists of materials which can be recycled, details of the used materials see chapter "Technical data - Mechanical data".

Recycling must be done by a specialised recycling company.