



Model 1221

Distillation Probe

Instruction Manual



TABLE OF CONTENTS

1.0	Notice	3
2.0	Definition of Symbols.....	4
3.0	Theory of Operation.....	5
4.0	Installation	8
4.1	Utilities.....	8
5.0	Probe Controllers	10
5.1	Pneumatic Controllers.....	10
5.1.1	Pneumatic Controller Layouts.....	10
5.1.2	Pneumatic Controller Operation.....	12
5.2	Electronic Controllers.....	13
5.2.1	Electronic Controller Layouts	13
5.2.2	Electronic Controller Overview.....	16
5.2.3	HMI Display and Operation	17
5.2.4	Network and Status Display.....	18
5.2.5	Primary Temperature Screen.....	18
5.2.6	Sample Isolation Valve Manual Operation Screen	19
5.2.7	Sample Temperature Setpoints Screen.....	20
5.2.8	Process Temperature Setpoints Screen	21
5.2.9	Coolant Dwell Timer Operation Screen	22
5.2.10	Enclosure Temperature Screen	24
5.2.11	Reset Factory Register Screen.....	24
5.2.12	Changing IP Address and Slave Number	25
5.2.13	SD Memory Card Data Logging and File Transfer.....	27
5.2.14	System Clock and Battery.....	29
5.2.15	Modbus.....	30
6.0	Start-Up.....	32
7.0	Maintenance.....	34
8.0	Troubleshooting.....	35
9.0	Drawings and Spare Parts.....	36
10.0	Standard Terms & Conditions of Sale and Warranty.....	37

1.0 Notice

This equipment is designed for industrial analytical applications. Individual installations may vary in scope. The installer should consult national, local, and plant construction codes to ensure that governing regulations are met.

When installing optional electronic control equipment, as a minimum, general installation precautions should be observed:

- Select a site that is free from direct sunlight, high temperature, or abrupt temperature variations.
- Select a site where the air is free from corrosive gases, or abrasive materials.
- The equipment should not be subjected to severe vibration. Protective mounts should be installed to isolate the equipment from excessive vibration.
- Do not install analyzer near equipment emitting electromagnetic interference.
- Electrical wiring should be installed according to the National Electrical Code and/or any other applicable local codes and regulations.
- Supply voltage should strictly adhere to the instrument specifications, be supplied from a stable, reliable source, and provided with proper ground connections.
- Signal connections should be made using shielded wiring.
- Signal, control, and interface wiring should be located separately from power supply lines.

Analyzer documentation should be consulted to determine sample transport options.

2.0 Definition of Symbols



CAUTION, RISK OF DANGER SYMBOL INDICATES INJURY MAY OCCUR IF MANUFACTURER'S INSTRUCTIONS ARE NOT ADHERED TO. PLEASE READ MANUAL CAREFULLY WHEN SYMBOL IS DISPLAYED



CAUTION, HOT SURFACE SYMBOL INDICATES EXPOSED SURFACE TEMPERATURE CAN CAUSE BURNS OR PERSONAL INJURY. CARE SHOULD BE TAKEN WHEN CONTACT IS REQUIRED.



CAUTION, RISK OF ELECTRICAL SHOCK SYMBOL INDICATES ELECTRICAL SHOCK MAY OCCUR. CAUTION SHOULD BE TAKEN BEFORE DISCONNECTING OR CONTACTING ANY ELECTRICAL CONNECTIONS.



PROTECTIVE CONDUCTOR TERMINAL SYMBOL INDICATES THE TERMINAL LOCATION FOR THE PROTECTIVE CONDUCTOR. FAILURE TO CONNECT TO THE PROTECTIVE CONDUCTOR TERMINAL MAY RESULT IN A SHOCK HAZARD.

3.0 Theory of Operation

All ethylene production facilities will employ some type of cracking furnace, which is used to convert saturated hydrocarbons found in the feed stock into unsaturated hydrocarbons or olefins, which are the basic building blocks used in a variety of chemicals produced downstream of the olefins plant. The process of cracking involves taking a gas feed stock such as 80% ethane / 20% propane or a light liquid hydrocarbon feedstock, and then diluting it with steam, which then heats it rapidly to 750–950°C. During this process, two hydrogen atoms are removed from ethane (C₂H₆) and propane (C₃H₈) resulting in the formation of ethylene (C₂H₄) and propylene (C₃H₆). In a typical cracking furnace, the residence time is reduced to milliseconds to improve yield, resulting in very high gas velocities through the furnace. After the cracking temperature has been reached, the gas is quickly quenched to stop the reaction in a transfer line heat exchanger.

The products produced in the reaction depend on the composition of the feed, the hydrocarbon-to-steam ratio, the cracking temperature, and residence time in the furnace. Light hydrocarbon feeds such as ethane / propane or light liquid feed stocks give product streams rich in the lighter alkenes, including ethylene and propylene. Heavier hydrocarbon feed stocks give some of these, but also produce products rich in aromatic hydrocarbons and hydrocarbons suitable for inclusion in gasoline or fuel oil. Higher cracking temperature results in the production of a higher ratio of ethylene, whereas lower cracking temperatures produce higher ratio of propylene.

The gas exiting the cracking furnace is often referred to as pyrolysis gas. For proper measurements of the chemical composition of this gas, the sampling (distillation) probe must deliver a gas sample to the analyzer, which is representative of the analytes being measured. In these locations where pyrolysis, decoke, or green oil (recycle gas) gas needs to be sampled, water and heavy hydrocarbons (i.e. C₆+) may be present and must be filtered out. If this material is allowed into the sample transport line or the primary sample conditioning system, reliability issues may occur, and hardware may become plugged or fouled, rendering the analytical results invalid. Allowing this unwanted material to travel into the analytical equipment itself can lead to expensive repair of the hardware. Proper setting of the distillation column temperature (typically 60-90°F) allows water and heavy molecular weight components (MW > 86) to form into droplets and fall back down into the process stream from which they came.

The process of conditioning the pyrolysis gas involves locating the sample probe vertically on the transfer line between the cracking furnace and the heat exchanger. At this point, the sample is extremely hot and will contain condensable materials, which when cooled, will result in the formation of liquid. A simple heat exchanger sampling probe must provide cooling of the process gas so that the content of condensable material can be significantly reduced or eliminated prior to entering the sample transport line used between the probe and the analyzer.

The Model 1221 Distillation Probe utilizes a countercurrent flow technique for cooling of the sample. Cooling medium flows in opposite direction of the process gas on the outside of the distillation column. Heat is conducted through the column wall and then transferred to the cooling medium. A series of discs, or “coalescing separator”, creates a tortuous pathway for sample gas as it rises through the column. Condensable materials coalesce on the interior wall of the column. This results in a distillation action, which involves the condensation of vapors and the return of this condensate to the system from which it originated. The condensable materials fall back down into the process pipe.

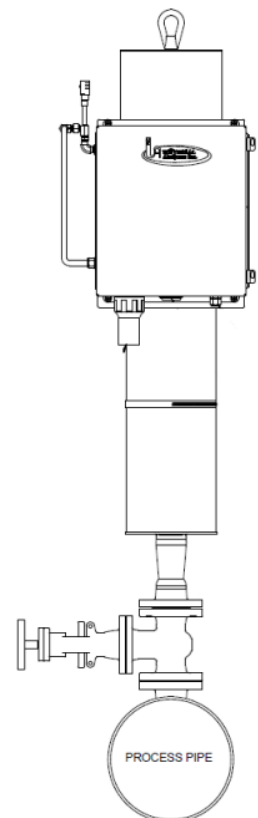

At the same time, the conditioned gas rises and exits the probe, where it is then introduced into the sample line for transport to the sample conditioning system and analysis by the analytical technique of choice.

The Model 1221 Distillation Probe separator column consists of a 2.5" schedule 80 pipe. Probe options allow for a few types of cooling mediums, which includes vortex cooled air, expanded refrigerant, or cool liquids such as water. Vortex cooled air is directed through a distribution manifold and travels through proprietary TraceBOOST™ technology pathways. With expanded refrigerant or liquid cooled probes, the cooling medium travels through tubing coiled around the outside of the column. A flange located on top of the column may be removed to access the separator discs for periodic inspection and cleaning. The bottom flange may be ordered to made with several different sizes of existing process nozzle flanges. The standard probe flanges may be ordered as either 150# or 300# to accommodate different process conditions. All components in the sample gas pathway are made from 316 stainless steel, including the coalescing separator discs.

As the gas enters the probe it encounters separator discs with a decreasing number of holes the further up it travels. The gas also gets colder as it travels upwards, dropping out more liquids and finer particulate. Liquids collected at each cooling stage drain back through the previous stages, essentially "self-cleaning" the discs below it. When the liquid travels below the bottom disc, it re-enters the process piping. The holes in each disc are not aligned with the discs below and above it, thus creating a tortuous path for the sample gas, increasing the distance it must travel in the column, and giving it more resonance time against a cold surface.

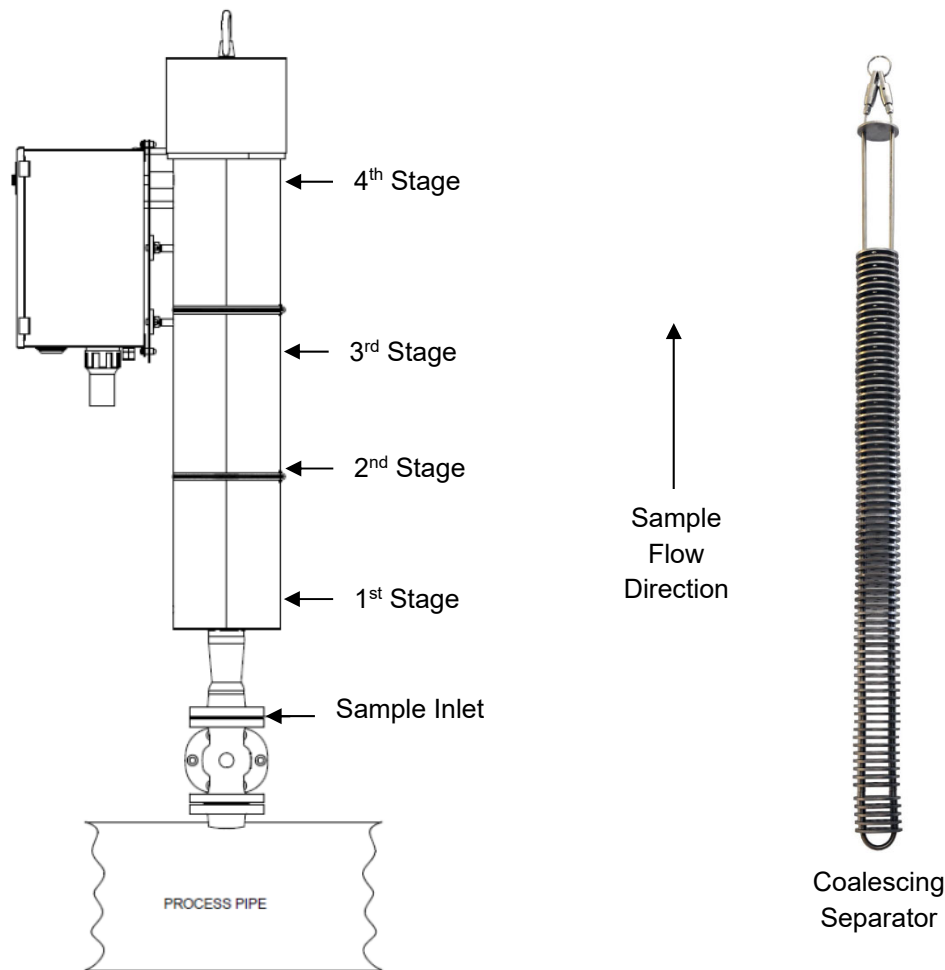

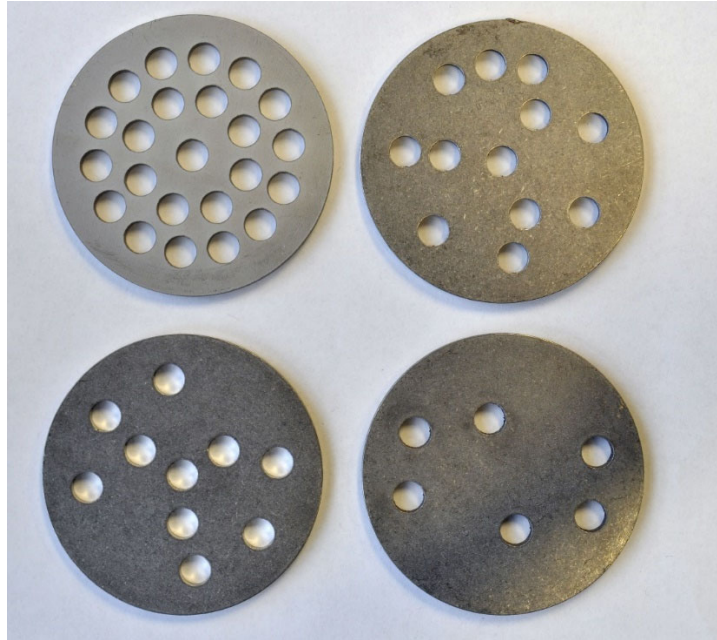

Various Separator Discs

When the sample gas enters the first stage of the probe, the gas and separator will be at its highest operating temperature. This is due to the counter current flow design of the sample (upwards) vs. the flow of the cooling medium (downwards). As the sample migrates through the column, it will lose velocity due to the random order of the holes found in the distillation discs. As the gas moves higher up into the column, it will continue to lose velocity and will progressively encounter cooler temperatures. The last stage is where the cooling medium is the coldest.

As the number of holes decreases in each successive stage through the column, this creates an upper area with the most surface area in the last cooling stage where the separator is operating at its lowest temperature. This has the net effect of increased cooling on the sample, thus bringing the molecules closer together, which in turn amplifies the coalescing effect.

Each probe is equipped with a controller which monitors the output temperature of the sample gas, and allows the cooling medium to flow accordingly. Pneumatic controllers require no electricity, and cool the sample to approximately +/- 5°F from the sample setpoint. Electronic controllers can be more accurate, regulating the sample temperature to approximately +/- 1°F.

Properly implemented, it will be possible to properly determine ethylene or propylene yield numbers at a consistent temperature. Each 1-degree Fahrenheit change in the temperature of the sample drives a change in the ethylene / propylene reading of approximately .1%, even though the actual yield from the furnace may have not changed. A stable sample temperature allows for plant operations to determine if the ethylene / propylene yield numbers are changing due to changes in cracking temperature, feed composition, or coking. An accurate sample system results in a better control algorithm to prevent over cracking, excessive coke, or lower yields when under cracking.

The high-performance separator design is ideal for use in applications such as ethylene furnaces, FCCUs and coke ovens. Combined with the dual vortex cooling system (feed-forward and feed-back control with the electronic controllers), the Model 1221 Distillation Probe guarantees high-accuracy analyzer performance and protection against liquid carry-over regardless of changes in ambient or process temperature.

4.0 Installation

Proper installation of the Model 1221 Distillation Probe will ensure optimum performance for the equipment and the analytical measurement technique of choice. For the best performance, the probe should be mounted on a horizontal process line with an isolation valve located between the process and the probe.

At the top of each probe, an eye nut is attached to the top flange with a threaded stud. This eye nut may be used to lift the probe. It's recommended to remove the insulator cap while lifting the probe to reduce the likelihood of damage. To remove the insulator cap, unscrew the eye nut and lift off.

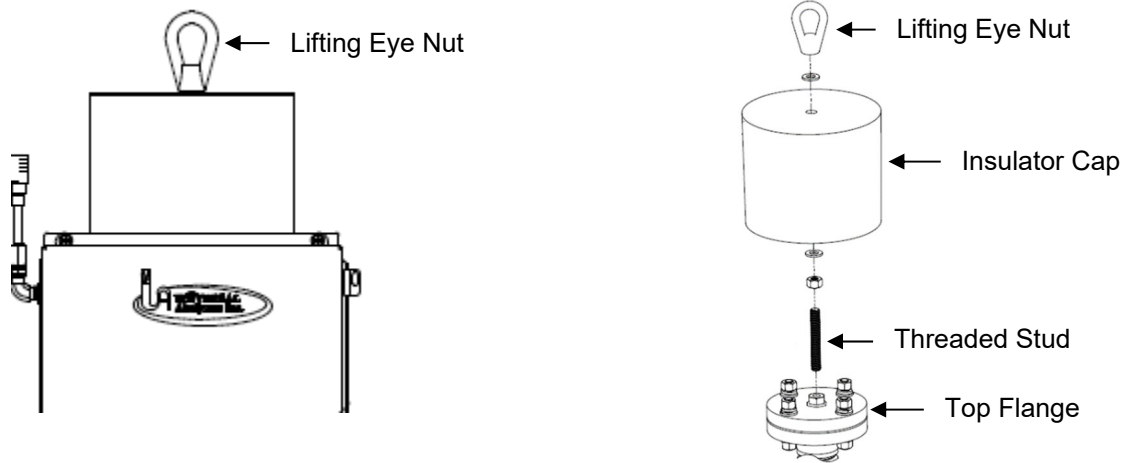

CAUTION: The eye nut and corresponding threaded stud are not permanently secured to the top flange. Before lifting the probe, ensure the nut and bolt stud are adequately secured to the flange. Also note that this eye nut is not directly over the center of gravity.

The probe will require a gasket installed between the isolation valve and the inlet of the probe. Torque the probe bottom flange per standard site procedures. The top flange has been torqued and sealed with a graphoil gasket at the factory. It's recommended to remove and re-torque this flange per site torque requirements if necessary. Factory torque values are 90 ft-lbs for 150# flanges, and 150 ft-lbs for 300# flanges, in ASME code patterns. It is recommended that after the probe is bolted to the gate valve, all connections be checked for leaks.

For electronically controlled probes, wiring diagrams are available for reference in the standard drawing package for each probe.

4.1 Utilities

The vortex air cooled probes, the following requirements apply:

- Inlet air pressure > 100 psig (80 psig minimum) at the probe
- Inlet air dew point recommended < -40°F
- Instrument air required to power the vortex = 40 SCFM (single vortex) and 80 SCFM (dual vortex)
- Maximum distance from main instrument air header to the probe is a function of air pressure drop.

Recommended Air Line Sizes

0-10 ft		10-50 ft		50-100 ft	
Pipe	Tube	Pipe	Tube	Pipe	Tube
1/4"	3/8"	1/2"	1/2"	1/2"	5/8"

Any reduction in utility requirements may render the probe inadequate to handle the application heat load.

For refrigerant and liquid cooled probes, utility requirements should be reviewed separately by a qualified Universal Analyzers representative.

5.0 Probe Controllers

The primary task of the Model 1221 Distillation Probe is to cool the sample gas to a desired temperature. The sample setpoint determines the average temperature of the sample gas, and is programmed in degrees Fahrenheit. Basic operation is to enable cooling when the gas temperature is above the desired setpoint, and disable cooling when it drops below the setpoint.

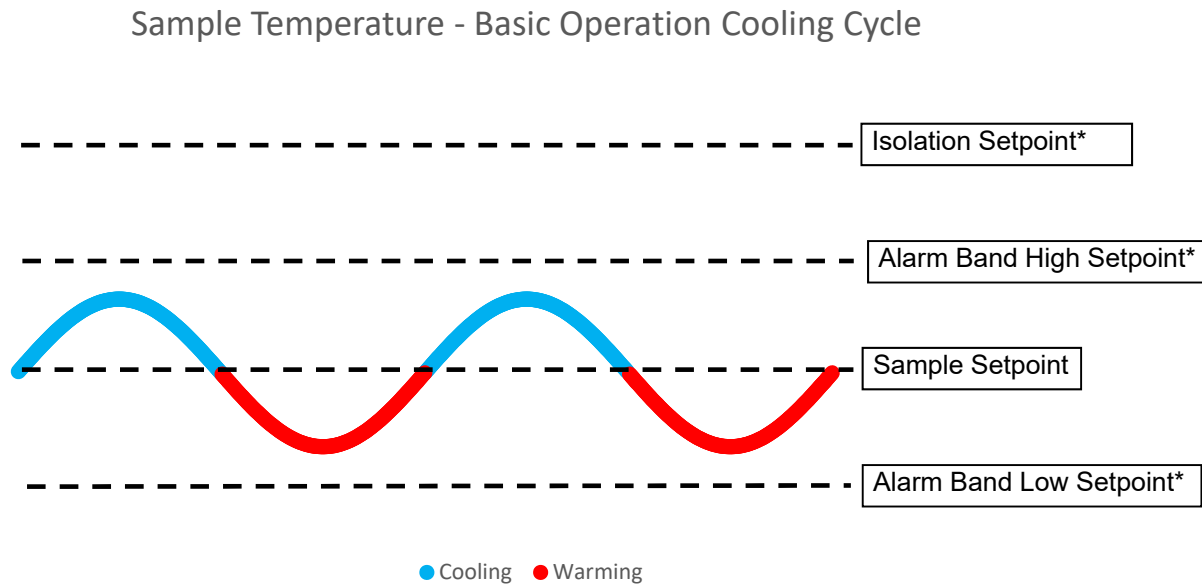

* Alarming is not available with pneumatic controllers.

5.1 Pneumatic Controllers

The pneumatic controllers do not contain any electrical components, thus do not require power wiring. These controllers have less functionality than electronic controllers and do not provide alarming, communications, or advanced controls. Pneumatic controllers are accurate to +/- 5°F on average.

5.1.1 Pneumatic Controller Layouts

The pneumatic controllers are available with single and dual vortex configurations. The general layout is the same for both, as they have mostly common components. The dual vortex unit requires two air feeds and has a second air relay.

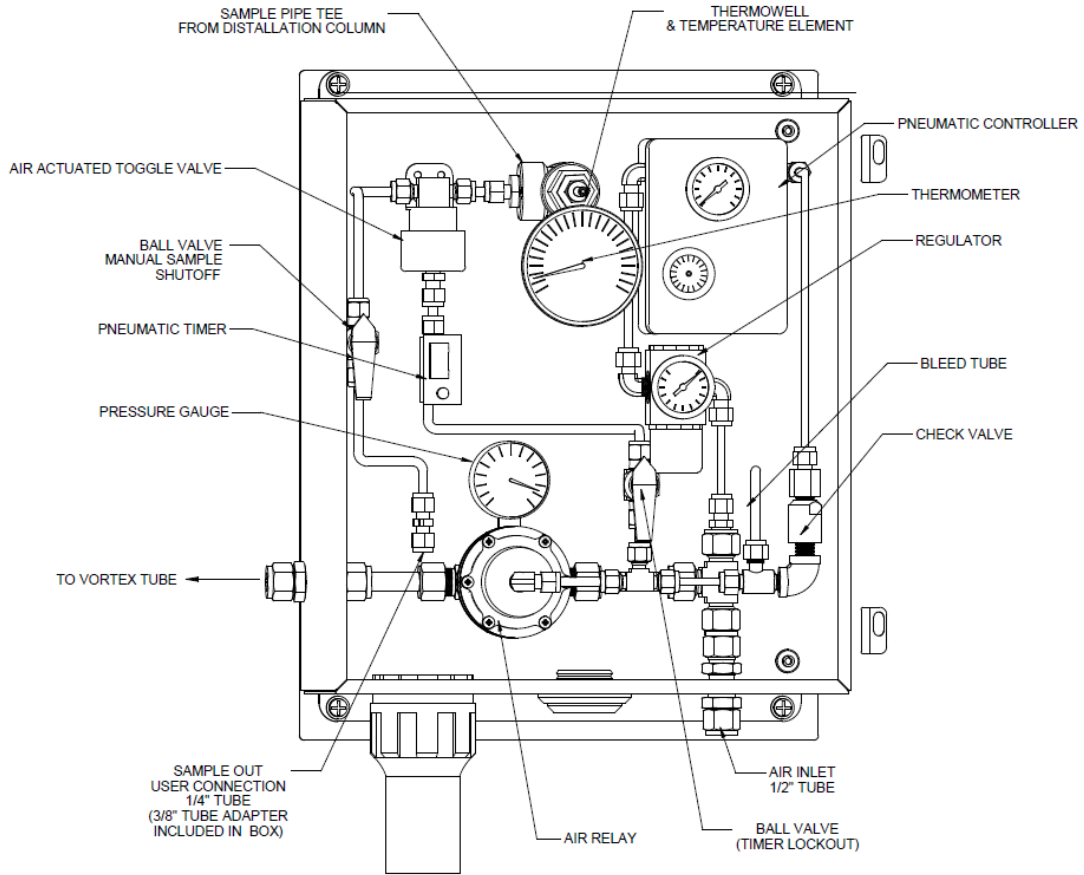

Single Vortex Control Box Layout

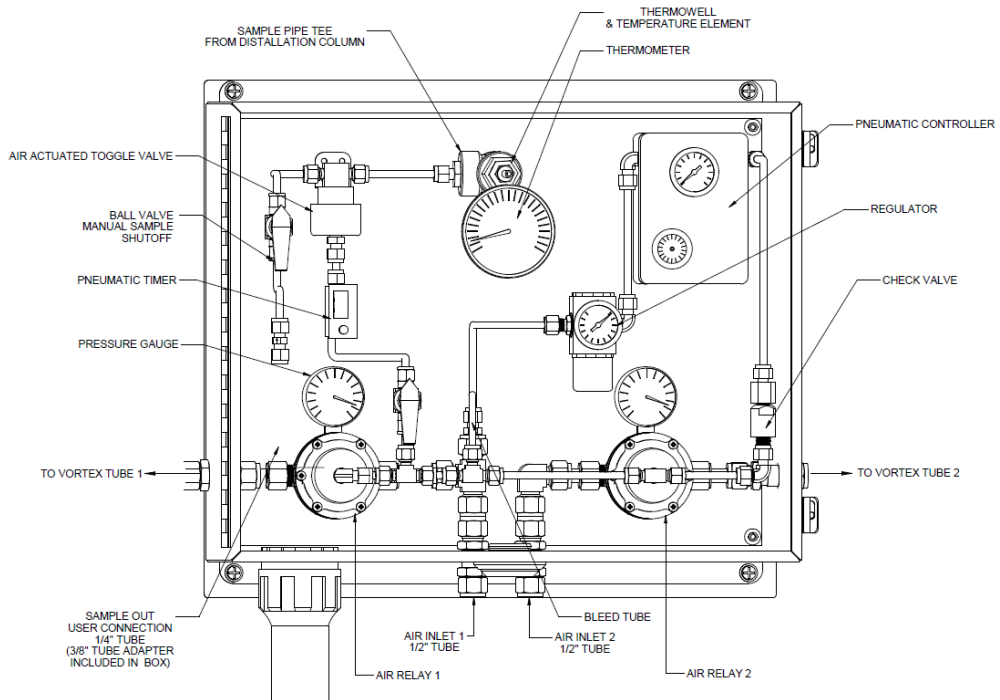

Dual Vortex Control Box Layout

5.1.2 Pneumatic Controller Operation

The pneumatic controller / vortex requires dry instrument air or N₂ with a dew point of less than -40°F at a pressure of 80-100 psig. Each vortex tube requires 40 SCFM while in operation.

Instrument air enters the system and is sent in two different directions. The unregulated air supply is sent to the pneumatic booster air relay and to a regulator which feeds the pneumatic temperature controller at 40 psig. The pneumatic temperature controller generates an output pressure dependent on the sample gas temperature. The output pressure is routed to a check valve with a 15 psig setting. If the sample gas temperature is below setpoint, the pneumatic output signal is at a pressure less than 15 psig, and the check valve is closed. Once the pneumatic signal exceeds 15 psig, the check valve opens, resulting in the air signal being sent to the control side of the air relay. The control side air pressure opens the internal valve, allowing air to flow to the vortex tube cooler.

Air from the pneumatic temperature controller is also routed to a pneumatic timer. The timer is preset at the factory to 300 seconds (5 minutes). Once pressurized, the timer begins counting down. Once the controller senses sample temperature is below the setpoint, it stops feeding pressurized air to the relay and timer. The remaining air pressure is reduced through a bleed tube, which closes the air relay and stops the timer from counting down. In a typical cycle, the sample temperature drops below the setpoint before the timer reaches zero. However, if the vortex supply signal is still “on” after five minutes, the pneumatic timer releases pressurized air to close a sample shut-off toggle valve (normally open), shutting off sample flow to the analyzer. This shut-off is to prevent liquid carryover from entering the sample transport line. Once the controller output pressure drops below 15 psig, the check valve closes, the timer resets, and the toggle valve reopens if it had closed. To override the automated sample shut-off valve, ensuring that the toggle valve stays open, close the ball valve to the timer.

Once the distillation probe is operating at setpoint, the vortex air is typically in the “On” state for 2-3 minutes and will remain in the “Off” state for 4-8 minutes before cycling back “On”. Ambient conditions and process temperature changes will result in a different cycling frequency.

The pneumatic temperature controller setpoint is set at the factory to 65°F, unless otherwise requested. To change the setpoint, remove the plastic cover from the temperature controller and rotate the dial to the desired value. The setpoint of the pneumatic controller can be set at any temperature between -10°F and 125°F.

The sensitivity of the pneumatic controller can be adjusted using the slide bar adjustment located on the right-hand side of the controller. The sensitivity adjustment is factory set and typically does not require adjustment. Moving the sensitivity slider bar in the “Up” direction results in the pneumatic signal reacting quicker to a change in temperature. Moving the sensitivity slider bar in the “Down” direction results in a lower acting response.

The output signal from the pneumatic controller is seen on the pressure gauge located on the controller. If the output pressure is less than 15 psig, then the vortex air and pneumatic timer will be “Off”. Once the air signal is greater than 15 psig, the vortex air supply will be “On” and the pneumatic timer will be in count down mode.

A manually operated ball valve is also located on the sample output tubing to allow for sample isolation.

Typical operating temperature for the distillation probe is 50-65F. Depending on the concentration of water or C₆+ hydrocarbons contained in the sample, the distillation probe separator can freeze up at temperatures less than 45°F.

5.2 Electronic Controllers

Electronically controlled probes have tighter accuracy around the sample setpoint than the pneumatic controllers, on average about +/- 1°F. Electric power is required, limiting the controllers to Class I, Division 2 hazardous areas and general-purpose applications. Modbus TCP and RS485 are available. The electronic controller includes self-diagnostics with local and remote monitoring and displays, configurable fail-safe alarms, and DCS integration, eliminating the need for regular, scheduled inspections.

The electronic controllers may be located remotely in an analyzer shelter, or locally in the box on the probe. PLC programming is the same for both options. The PLC hardware has ambient temperature restrictions, limited to environments between 14°F and 130°F. Remote controlled option allows the PLC to be in a temperature controlled environment, more suitable for electronic equipment. If locally controlled options are used, ensure the control box is not installed in direct sunlight in hot environments, and that the box has adequate ventilation to keep it cool. Care must also be given to keep the control box warm when located in cold environments if temperatures get too cold.

The electronic controllers with vortex cooling tubes require dry instrument air with a dew point of less than -40°F at a pressure of 80-100 psig. Each vortex tube requires 40 SCFM while in operation. Refrigerant and liquid cooled probes require instrument air at a pressure of 80-115 psig for air operated ball valves and the sample shut-off toggle valve.

Typical operating temperature for the distillation probe is 50-65F. Depending on the concentration of water or C6+ hydrocarbons contained in the sample, the distillation probe separator can freeze up at temperatures less than 45°F.

5.2.1 Electronic Controller Layouts

The electronic controllers are available with single and dual vortex configurations. The general layout is the same for both, as they have mostly common components. The dual vortex unit requires two air feeds and has a second air control solenoid valve. Remotely Controlled (RC) probes require a separately located PLC, and are better suited for harsh locations and temperatures. Locally Controlled (LC) probes have all required PLC hardware at the probe, but have operating temperature restrictions of 14°F to 130°F.

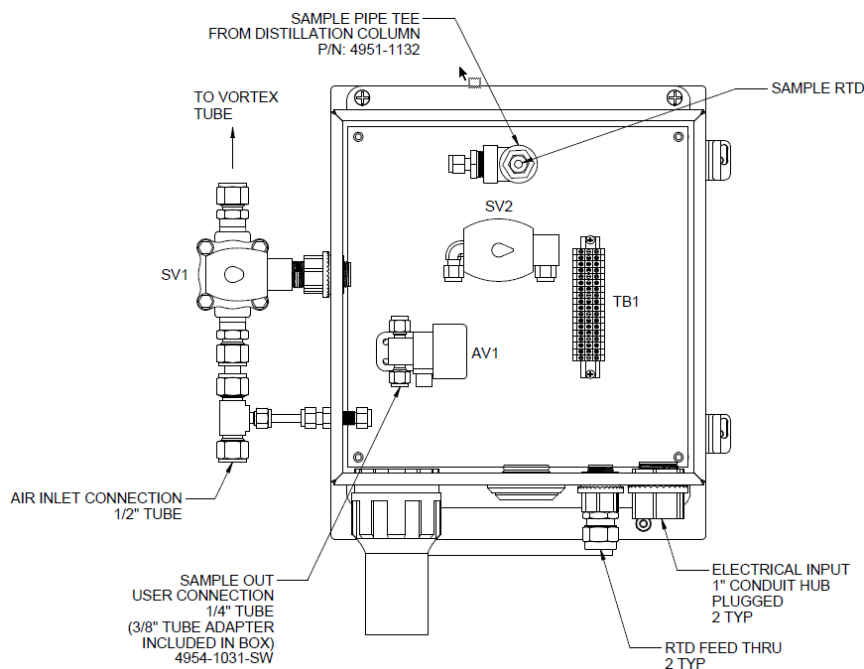

Single Vortex RC Probe Layout

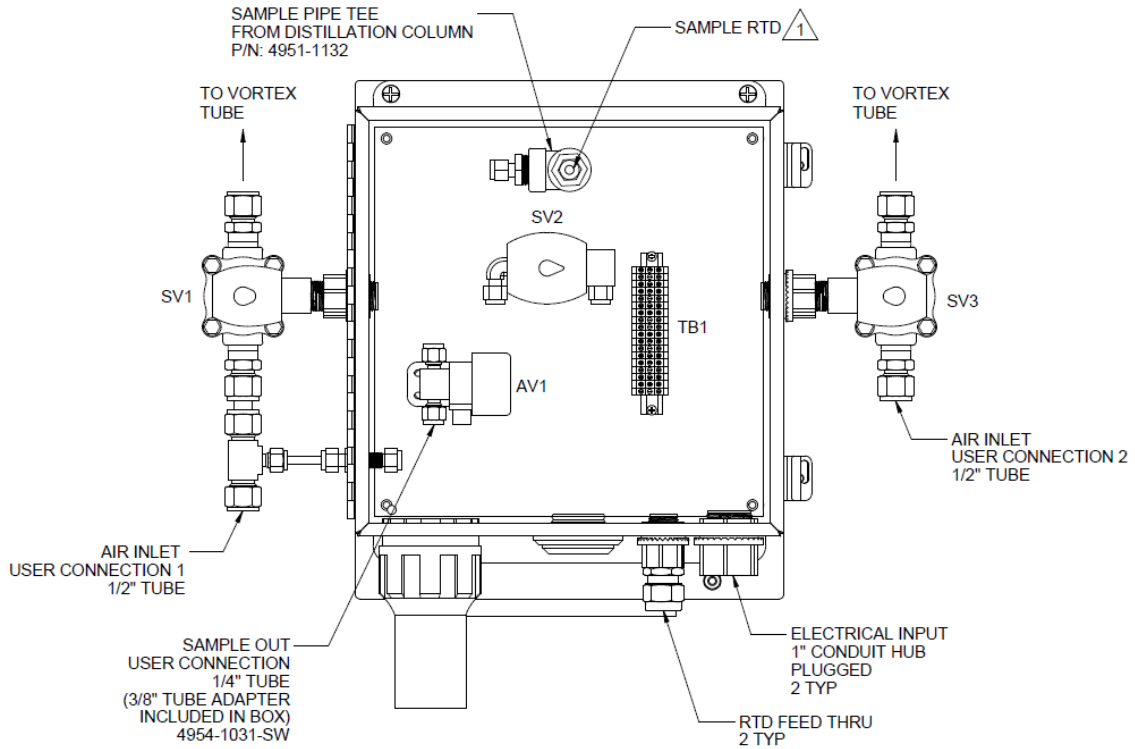

Dual Vortex RC Probe Layout

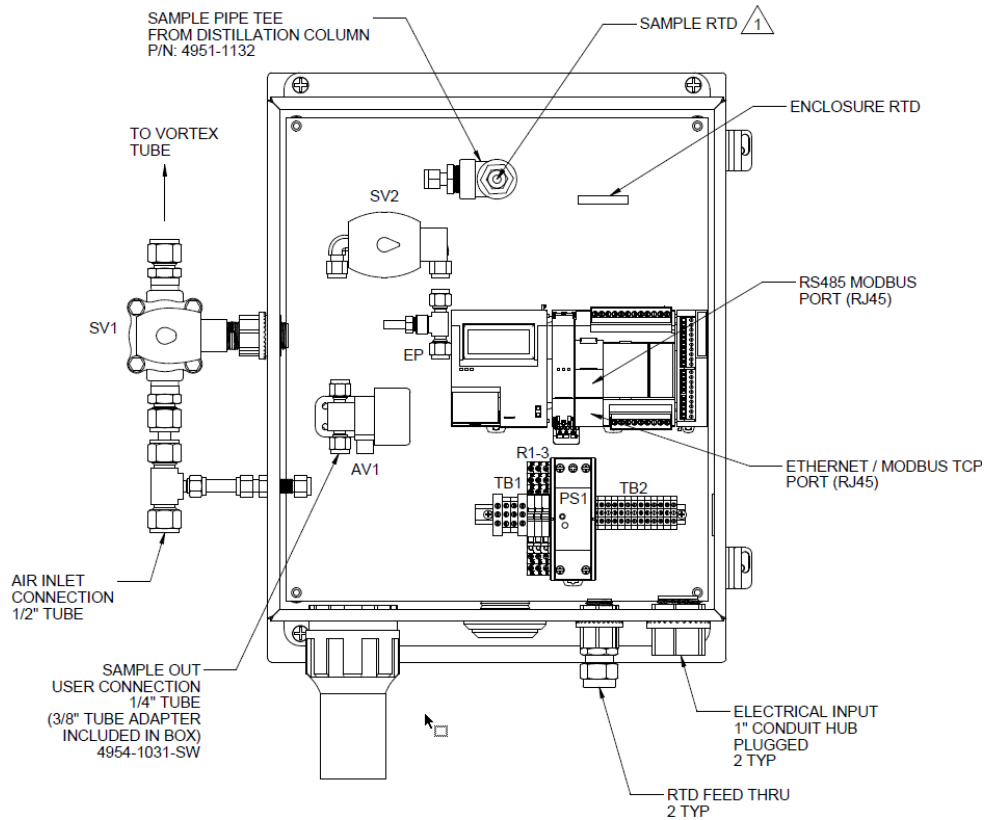

Single Vortex LC Probe Layout

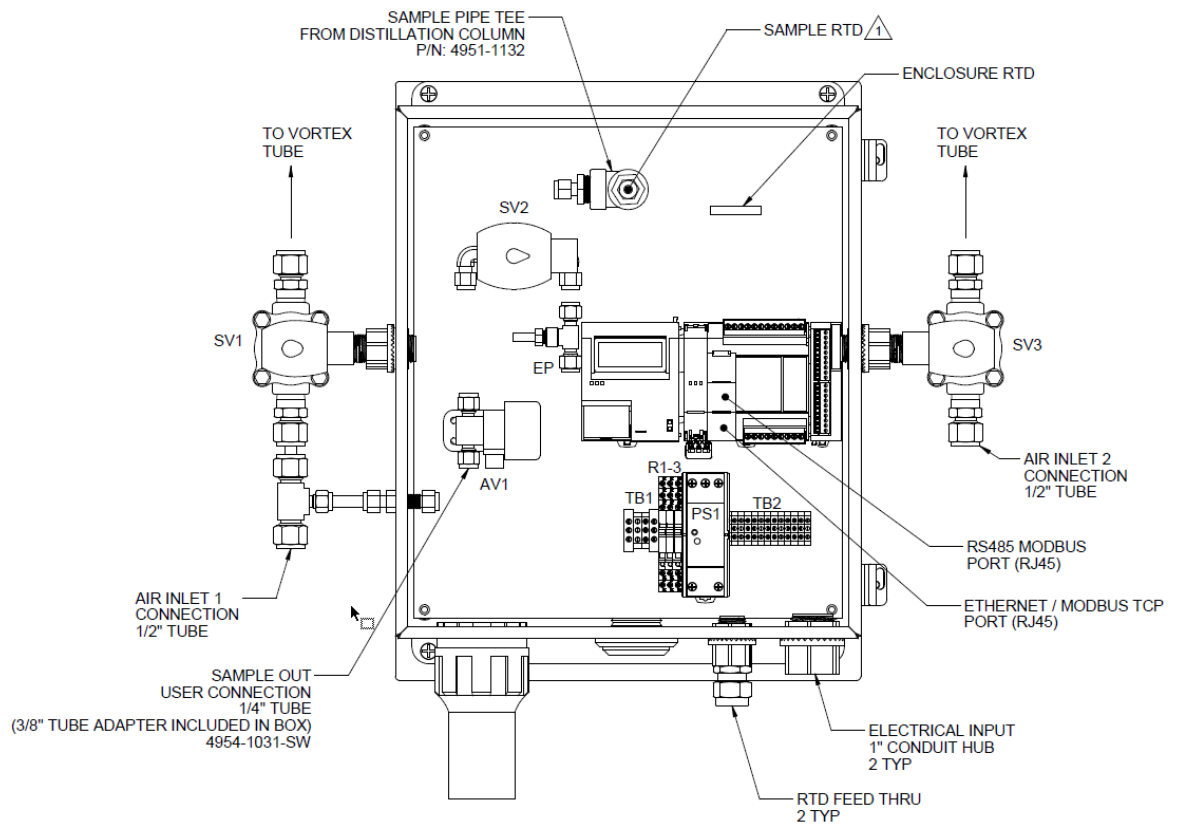

Dual Vortex LC Probe Layout

5.2.2 Electronic Controller Overview

All electronic controllers are based on the IDEC microSmart FC6A PLC.

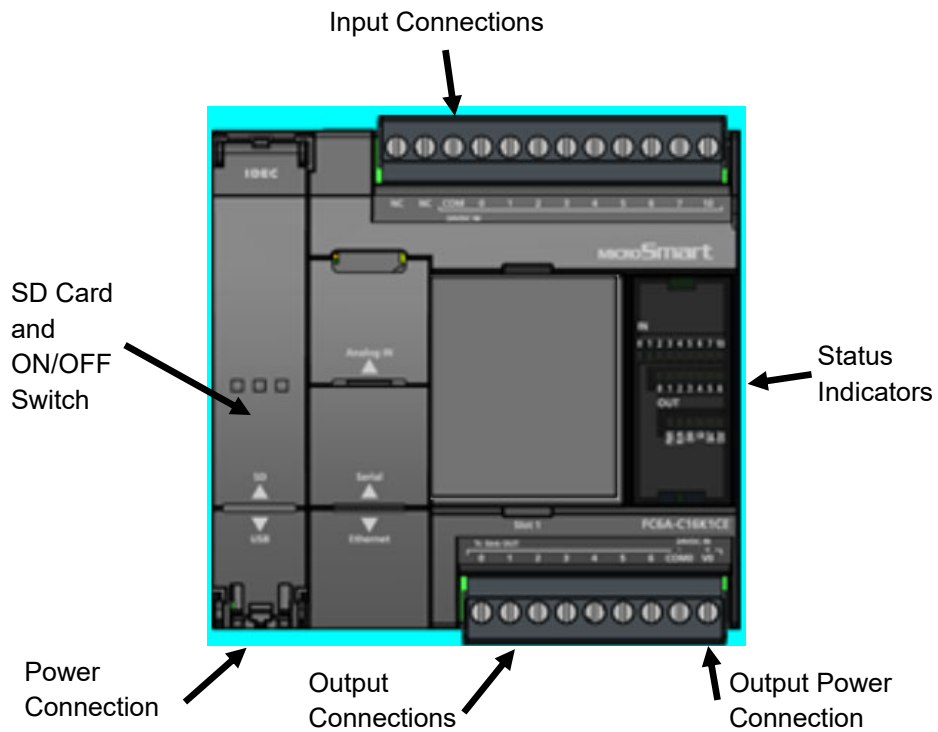

RTDs are connected to the PLC via an FC6A-J4CN1, 4 channel input module, located to the right of the PLC. Sensors are connected to the module as follows:

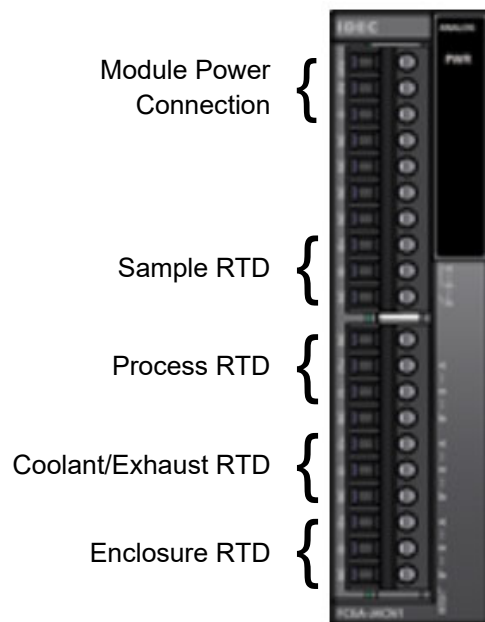

5.2.3 HMI Display and Operation

The IDEC FC6A-PH1 provides local control and display, and is located on the left side of the PLC. The Ethernet port located on the bottom side of this module is programmed at the factory: 192.168.1.25. This connection may be used to view and control the PLC from a remote computer but does not communicate Modbus values and is not practical for usage by most customers.

To connect to the HMI with most standard web browsers, use the IP address listed above with the login “User” and password “1221”.

The screen shown below is the Home screen for the PLC. This screen shows if the PLC is “Running” or “Stopped”, along with the current date and time set in the module. The six buttons used to manipulate and change settings in the PLC are indicated below.

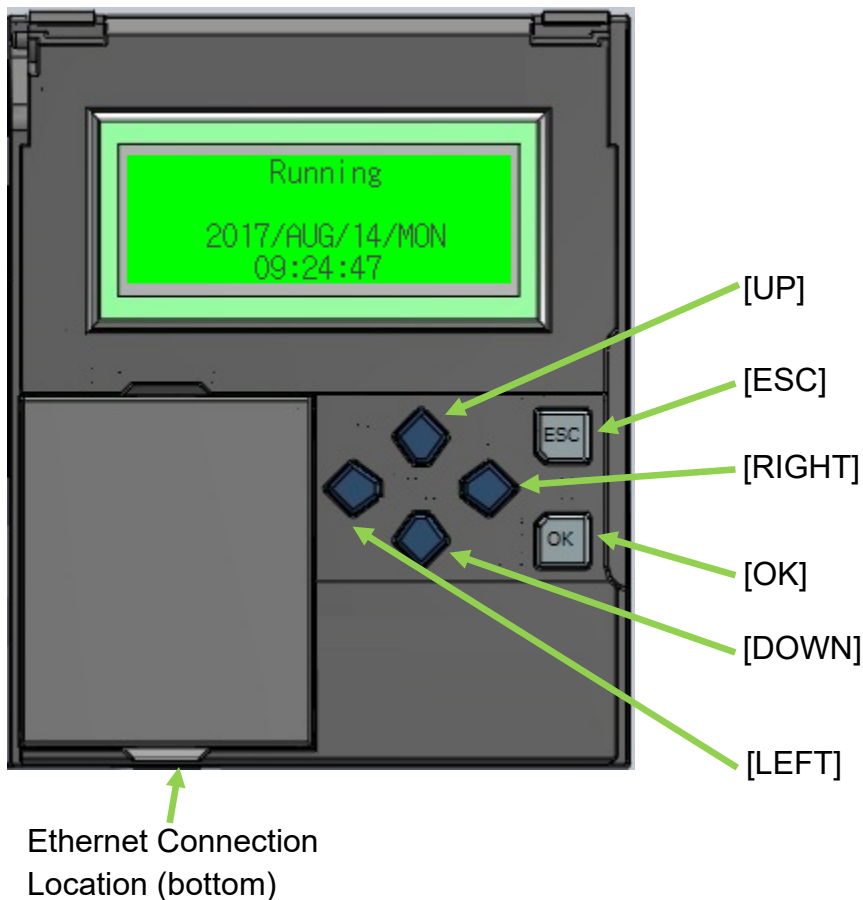

For the purpose of this manual, when text appears in square brackets [] this indicates the button on the display module which is to be pushed, and will correspond to the buttons indicated to the above picture. Multiple bracketed texts indicate a sequence of button pushes, in the order in which they are read. Moving from screen to screen requires pushing the [UP] and [DOWN] buttons. Text appearing in ALL CAPITAL letters is related to what is directly written on the PLC display.

When a setting is to be modified, the [OK] button must be held for greater than 3 seconds. This will be indicated as [OK-HOLD].

5.2.4 Network and Status Display

The FC6A-PH1 has an internal system menu, which displays current information for registers, as well as network. To access the system menu, press **[ESC-HOLD] + [OK-HOLD]** at the same time. The **[ESC]** button should be pressed slightly before the **[OK]** button is pressed.

The DEVICE MONITOR menu provides current values of all internal registers in the PLC. The STATUS MONITOR menu provides network setting information.

5.2.5 Primary Temperature Screen

SAMPLE, PROCESS, COOLANT/EXHAUST and ENCLOSURE temperatures are viewed from the primary temperature screen.



SAMPLE	65.6°F
PROCESS	135.8°F
COOL EXH	76.7°F
ENCLOSURE	76°F

No setting changes may be made from this screen, however active alarms and other statuses will be indicated on the bottom row of text, displacing the ENCLOSURE temperature row. The COOLANT/EXHAUST row will display the ENCLOSURE temperature when enclosure alarms are active. The below picture shows the SAMPLE HIGH TEMPERATURE alarm on screen (flashing), before it has been acknowledged.

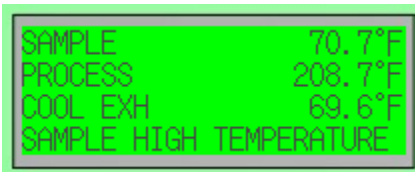

SAMPLE	70.7°F
PROCESS	208.7°F
COOL EXH	69.6°F
SAMPLE HIGH TEMPERATURE	

The alarm message will continue to flash until it has been acknowledged, even if the alarm conditions are no longer present. If alarm conditions are no longer present, and a specific alarm message is flashing, scrolling will be disabled until the message is acknowledged. If a specific alarm message is being displayed and the alarm conditions are still present, scrolling is enabled to view other alarm messages, status messages, and other screens. To acknowledge an alarm, press **[OK]**. If the alarm conditions are still present, the general alarm message "ALARM" will continue to flash in the bottom row on the screen. Once the alarm condition clears, the general alarm message will clear. The general alarm is always active when any other alarm or NOT OK status is active.



SAMPLE	68.6°F
PROCESS	135.8°F
COOL EXH	77.2°F
ALARM	

If multiple, specific alarms are present, scroll **[UP]** and **[DOWN]** to view the various alarms. Pressing **[OK]** will acknowledge the alarm being displayed. Repeat until all alarms have been acknowledged.

5.2.6 Sample Isolation Valve Manual Operation Screen

The sample isolation valve in an electronically controlled probe is a normally closed valve. It requires both power/signal from the PLC and the required air pressure to open the valve to allow sample to flow. The valve will close with loss of either power or air pressure.

The SAMPLE VALVE MANUAL OPERATION screen allows the valve to be forced to remain open or forced to remain closed. These operations override all other PLC controls of the sample valve. The FORCED OPEN command will not open the valve if no air pressure is present.



When FORCED OPEN is enabled, the valve will remain open even if the sample isolation alarm, process isolation alarm, or if the isolation input contact is closed. FORCED OPEN does not enable the general alarm, but does enable Output #6 (not wired to the terminal strip). Typical applications of the FORCED OPEN command include:

- Allow process gas to flow across the sample temperature RTD to speed up the startup procedure
- Get flow to the analyzer under all conditions

When FORCED CLOSED is enabled, the valve will remain shut. FORCED CLOSED enables the general alarm, and "SAMPLE VALVE FORCED CLOSED" will flash on the screen. Typical applications of the FORCED CLOSED command include:

- Stop flow during decoke or abnormal conditions
- Sample line not connected
- Maintenance activities

The RESET ENTER operation will disable either FORCED OPEN or FORCED CLOSED. The reset register automatically resets itself to zero.

To enable any of the operations on this screen, press **[OK-HOLD]**, **[DOWN]** to the desired operation, **[OK]**, **[RIGHT]** 4 times, **[UP]**, **[OK]**. The FORCED CLOSED sequence is shown below:

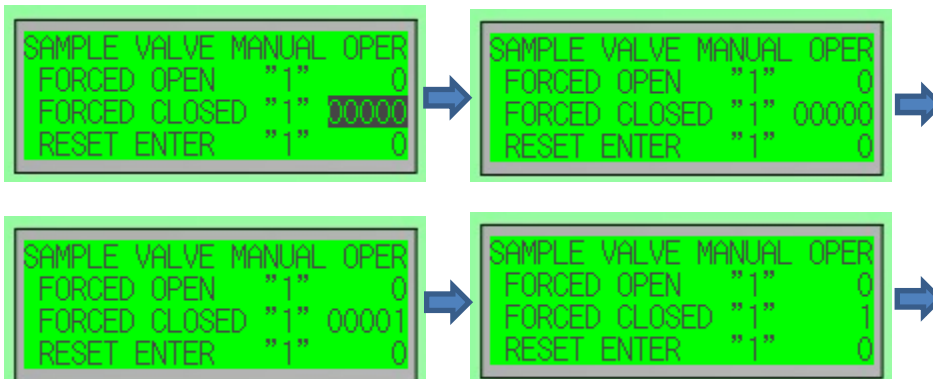

SAMPLE	70.6°F
PROCESS	206.7°F
COOL EXH	73.8°F
SAMPLE VALV FORCED CLOSED	

FORCED CLOSED may not be enabled when FORCED OPEN is currently enabled. Enabling FORCED OPEN when FORCED CLOSED is currently enabled will disable FORCED CLOSED.

CAUTION: If FORCED OPEN is enabled, the PLC cannot automatically shut off the sample flow to avoid a high temperature liquid carryover.

5.2.7 Sample Temperature Setpoints Screen

The primary task of the Model 1221 Distillation Probe is to cool the sample gas to the desired temperature. The SAMPLE SETPOINT determines the average temperature of the sample gas, and is programmed in degrees Fahrenheit. Basic operation is to enable cooling when the gas temperature is over the desired setpoint, and disable cooling when it drops below the setpoint. An ALARM BAND is provided to indicate when the temperature is outside of the desired window around the SAMPLE SETPOINT. To help avoid liquid carryover, an over-temperature ISOLATION HIGH setpoint may be configured to close the sample isolation valve when the temperature gets even further beyond the SAMPLE SETPOINT. A HYSTERESIS may be set for situations with a noisy signal or temperature hovers around the sample setpoint and the cooling solenoid valve is opening and closing too frequently.

The ALARM BAND, HYSTERESIS, and ISOLATION HIGH alarms are configured as a difference, or delta, to the SAMPLE SETPOINT. The ALARM BAND is both positive (above) and negative (below) from the SAMPLE SETPOINT. The ISOLATION HIGH setpoint is only positive (above) from the SAMPLE SETPOINT. The HYSTERESIS is only negative (below) the SAMPLE SETPOINT. For example, if the SAMPLE SETPOINT is set at 65°F, and the ISOLATION HIGH setpoint is set at 10°F, the isolation valve will close when the sample temperature reaches 75°F. The ALARM BAND and ISOLATION HIGH alarms have 3 second time delays.

SAMPLE SET	65
HYSTERSIS	0
ALARM BAND	5
ISOLATE HI	10

There is always a lag between the cooling cycle operation and response to the sample temperature. This can vary based on process gas temperatures, ambient humidity and temperatures, and process gas flow rates. This is also due to material mass of the probe, properties of the process gases, and inlet temperature of the coolant medium. The greater the lag, the greater the temperature cycles above and below the sample setpoint. The lag creates a temperature “momentum” which pushes the sample gas temperature to the high and low points in the cycle, as much as several minutes after warming and cooling has stopped. The effectiveness of the probe and the setpoints in the controller help to minimize the temperature differential above and below the sample setpoint.

The hysteresis feature drives the cooling temperature down below the sample setpoint by the configured amount. The cooling cycle always starts at the sample setpoint on the up-swing, but will not shut off until the temperature reaches the sample setpoint minus the hysteresis. The effect of hysteresis is shown in the following graph:

Sample Temperature - Cooling Cycle with Hysteresis

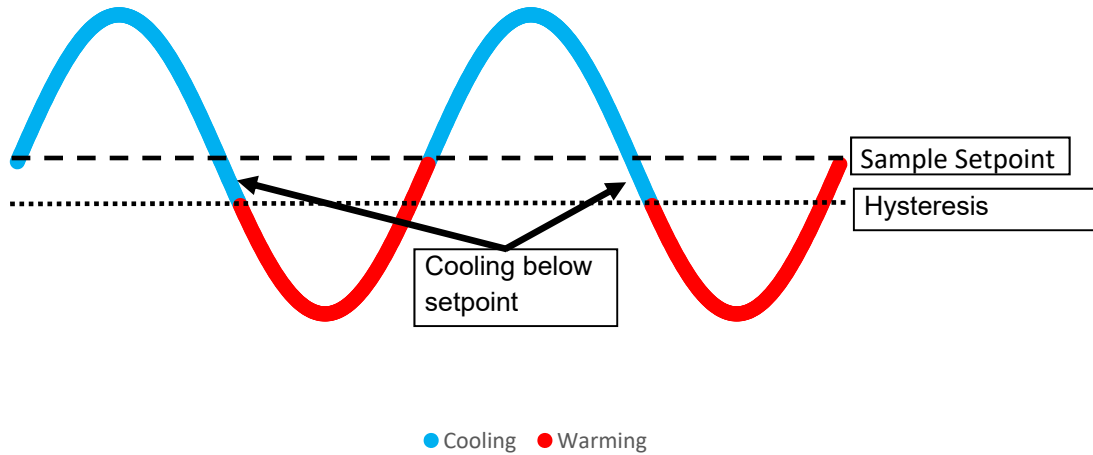

All the temperature setpoints on this screen are configured with exponential notation. To change any setpoints on this screen, press **[OK-HOLD]**, **[DOWN]** to the desired setpoint, **[OK]**, **[RIGHT]** to the appropriate numeral, **[UP]** or **[DOWN]** to the desired setting, **[OK]**. Changing the Sample Setpoint from 65°F to 70°F is shown below:

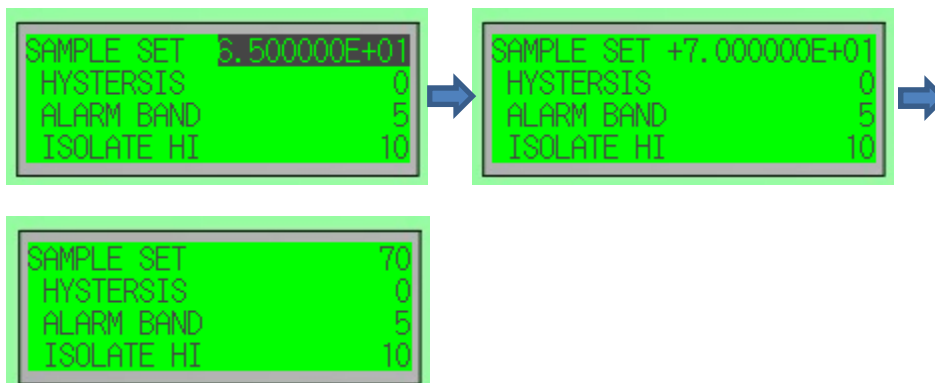

There are a couple rules for the ISOLATION HIGH setpoint embedded in the PLC.

1. The ISOLATION HIGH setpoint cannot be set less than 5 degrees above the sample setpoint. This helps to avoid unwanted sample valve closures.
2. The ISOLATION HIGH setpoint must always be greater than the ALARM BAND high setpoint. If this situation is detected, the PLC automatically adjusts the ISOLATION HIGH setpoint to be 1 degree above the ALARM BAND high setpoint.

5.2.8 Process Temperature Setpoints Screen

The process alarm and isolation setpoints provide warning and sample isolation valve shutoff when the inlet process temperature gets too high. The default factory values for these setpoints are well beyond normal process temperatures, which are essentially turned “OFF”.

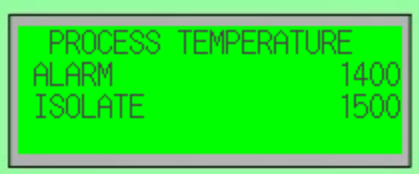

To change any setpoints on this screen, press **[OK-HOLD]**, **[DOWN]** to the desired setpoint, **[OK]**, **[RIGHT]** to the appropriate numeral, **[UP]** or **[DOWN]** to the desired setting, **[OK]**. Changing the Alarm Setpoint from 1400°F to 250°F is shown below:



5.2.9 Coolant Dwell Timer Operation Screen

If the cooling medium is extremely cold (i.e. refrigerant cooled probes) or is more effective at transferring BTUs from the distillation column (i.e. water cooled probes), the cooling cycle can drive sample gas temperatures well below the desired values. Coolant dwell timers may be used to mitigate these special circumstances. The cooling portion of the cycle may be shortened, to stop cooling before the temperature makes it back down to the sample setpoint, where it would normally be shut off.

Sample Temperature - Temperature Drop Too Low

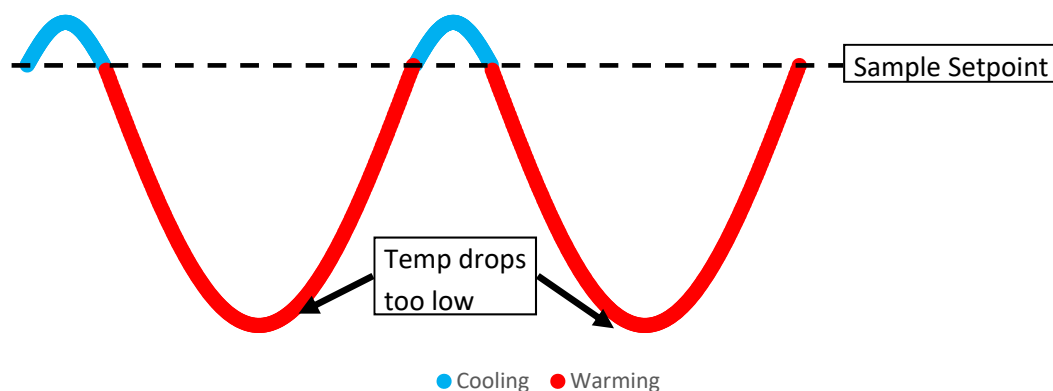

The dwell timer settings are in units of seconds. When enabled, the COOLANT ON dwell timer starts when the sample temperature rises above the sample setpoint, which coincides with the activation of probe cooling. Probe cooling stops when the timer expires.

The COOLANT ON timer should be set to expire while the sample temperature is still above the sample setpoint. The sample temperature should continue to drop below the sample setpoint.

Once the COOLANT ON timer expires, the COOLANT OFF timer begins. It is expected that the sample temperature drops below the sample setpoint before the COOLANT OFF timer expires. If the sample temperature is still above the sample setpoint when the COOLANT OFF timer expires, the COOLANT ON timer restarts, and cooling is enabled again. In this scenario, the COOLANT ON time should be increased or the COOLANT OFF time should be decreased. If the sample temperature rises to more than 5°F above the sample setpoint, the dwell timers are disabled, and cooling remains enabled until it drops back to within 5°F.

Setting the timers should be done empirically, and will be different for each application. Several cycles of testing and adjustments may be required. The sample temperature should always drop below the sample setpoint, but only by an acceptable level.

Dwell timers are typically disabled when shipped from the factory. The timers are disabled when a value of 5 seconds or less is entered in the COOLANT ON timer value.

Cooling Cycle with Coolant Dwell Timer

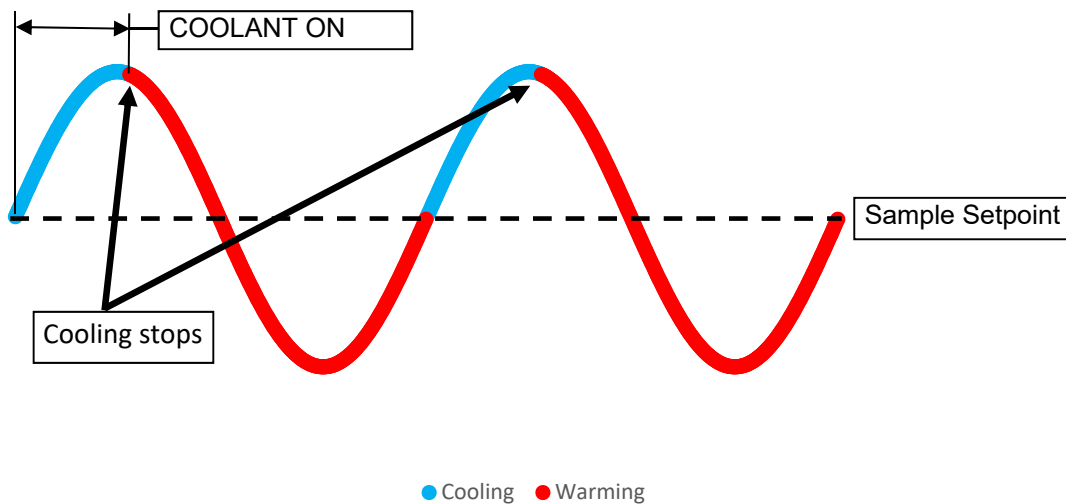

To change timer settings on this screen, press **[OK-HOLD]**, **[DOWN]** to the desired timer, **[OK]**, **[RIGHT]** to the appropriate numeral, **[UP]** or **[DOWN]** to the desired setting, **[OK]**. Changing the COOLANT ON timer to 10 seconds is shown below:

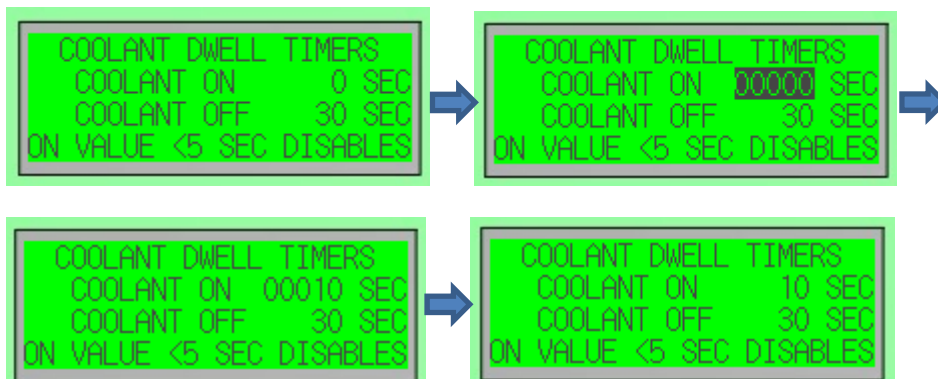

5.2.10 Enclosure Temperature Screen

The enclosure temperature RTD monitors the ambient temperature inside the probe enclosure. This measurement can be critical if ambient temperatures fall outside the operating temperature range of the PLC. The alarming is only applicable when a Local Control (LC) configuration is ordered with the probe. Care should be taken to shade these enclosures from direct sunlight, as well as ensuring that local weather temperatures do not drop below the minimum operating temperature. The operating temperature for the PLC is between 14°F and 130°F, and these are the default values for alarms from the factory.

In addition to alarming, the minimum and maximum enclosure temperature values are stored in the PLC. The “RESET LOG” feature clears the current high and low log values and starts recording at the current temperature. The lowest value that the low log will display is zero.

To change alarm settings on this screen, press [OK-HOLD], [DOWN] to the desired alarm, [OK], [RIGHT] to the appropriate numeral, [UP] or [DOWN] to the desired setting, [OK]. Changing the HIGH Temperature alarm to 110°F is shown below:



When resetting the log values, a “1” is entered. The value resets itself to “0” when complete.

5.2.11 Reset Factory Register Screen

Unless otherwise specified on the PO when ordered, the electronic controllers are set to specific factory default values. These values are programmed into every unit, and are as follows:

Parameter	Value	Units
Sample Temp Setpoint	65	Deg F
Sample Temp Hysteresis	0	Deg F
Sample Temp Alarm Band	5	Deg F
Sample Temp Isolation Alarm	10	Deg F
Sample Valve Forced Open	0	n/a
Sample Valve Forced Closed	0	n/a
Process Temp High Alarm	1400	Deg F
Process Temp Isolation Alarm	1500	Deg F
Dwell Timer Coolant On	0*	Seconds
Dwell Timer Coolant Off	30	Seconds
Enclosure Temp Low Alarm	14**	Deg F
Enclosure Temp High Alarm	130**	Deg F
Data Logging Enabled	1	n/a
Data Logging Freq. Timer	10	Seconds

Modbus Slave Number	1	n/a
CPU IP Address:	192.168.0.1	n/a
HMI IP Address:	192.168.1.25	n/a

*The dwell timers are turned off by default, since the default value is below 5 seconds.

**The enclosure temperature alarm values are based on the operating temperatures of the PLC.

To reset the PLC to the factory default values, press **[OK-HOLD]**, **[OK]**, **[RIGHT]** 4 times, **[UP]**, **[OK]**. The reset value will automatically reset to 0. The sequence is shown below:

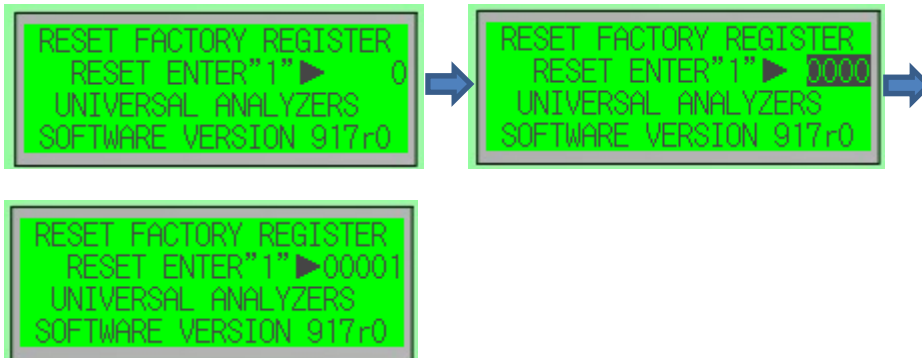

The program version will be displayed on the

5.2.12 Changing IP Address and Slave Number

Scroll **[DOWN]** to the Home Screen. Press **[ESC-HOLD]** + **[OK-HOLD]** to access the system menu. The **[ESC]** button should be pressed slightly before the **[OK]** button is pressed. The network settings and slave number may only be changed with the PLC stopped. With the arrow pointing to the "Stop" command, press **[OK]**. Scroll **[DOWN]** on the next screen to select "Yes", and press **[OK]** to stop the PLC. The PLC will exit the menu and revert to the Home screen, and should display "Stopped".

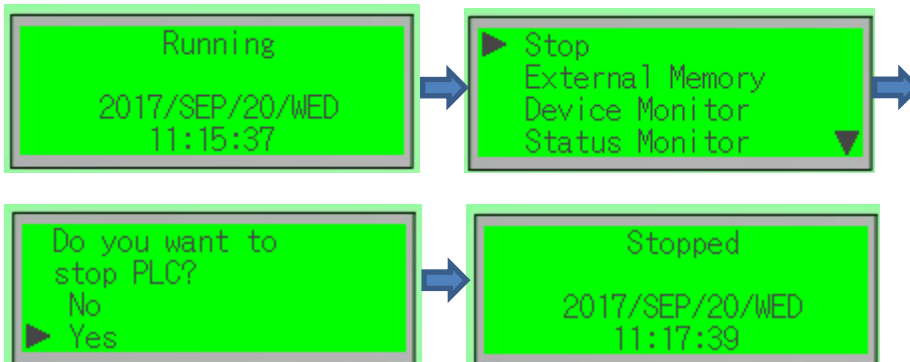

Press **[ESC-HOLD]** + **[OK-HOLD]** to access the system menu. The **[ESC]** button should be pressed slightly before the **[OK]** button is pressed. Scroll **[DOWN]** until the arrow points to the "Configurations" selection and press **[OK]**. Press **[OK]** to select "Function". Press **[OK]** to select "Communications". Scroll **[DOWN]** to the desired function screen and press **[OK]**.

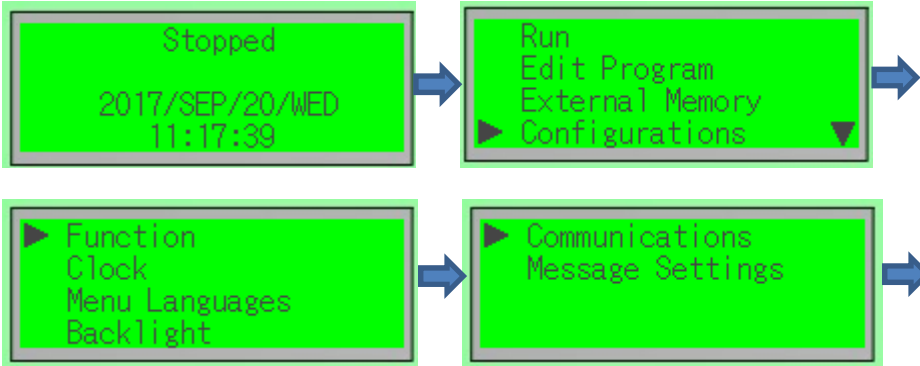

To change the slave number, select “Slave Number” by pressing **[OK]**. Select the Port 1 setting by pressing **[OK]** (other ports may be selected by pressing **[UP]** or **[DOWN]**). The slave number will flash, and may be set by pressing the **[UP]** or **[DOWN]** arrows. The slave number may be set as 1 to 247. After the correct number is shown, press **[OK]**.

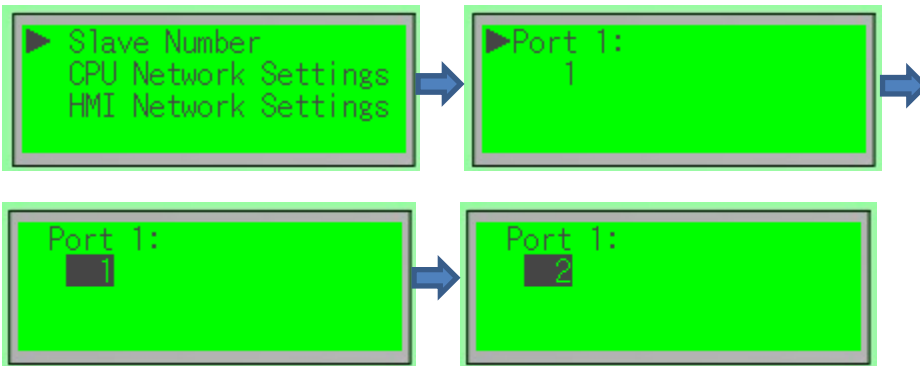

To change the IP Address of the PLC, after selecting “Communications”, scroll **[DOWN]** to “CPU Network Settings” and press **[OK]**. Scroll down once to the “IP Address:” line, and press **[OK]**. On the IP Address screen, scroll **[LEFT]** or **[RIGHT]** to select the proper value, then scroll **[UP]** or **[DOWN]** to change the value. Press **[OK]** to set the IP Address to the new value, and exit back to the CPU Network Settings screen. Press **[ESC]** to exit out of the settings screen. Scroll down to “Yes” and press **[OK]** to save the configuration. The Subnet Mask, Default Gateway, and Primary and Secondary DNS server addresses may also be changed in this menu.

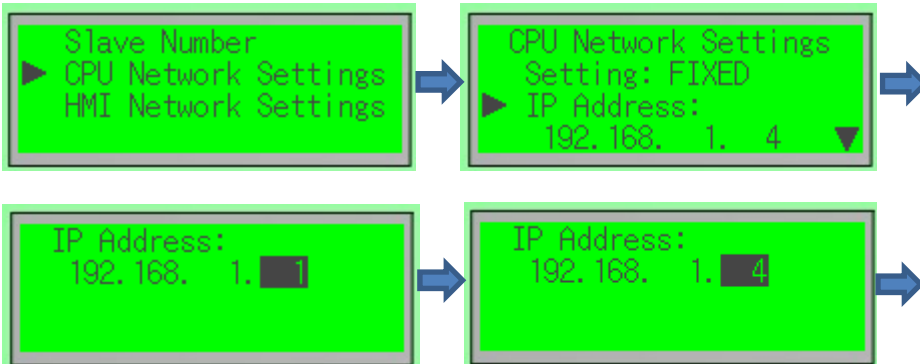

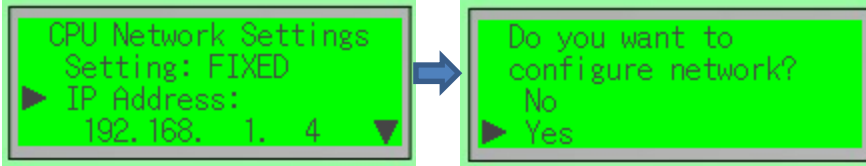

Press **[ESC]** multiple times to exit out of the system menu. Be sure to change the PLC status back to “Run” before exiting.

5.2.13 SD Memory Card Data Logging and File Transfer

An SD memory card is provided with each PLC. This card is loaded at the factory with the current programming file and the current system software (firmware) file, which are combined into one file with a .ZLD extension. Some data logging may also have been stored on the card during quality assurance testing. This card may be used to log data, upload and store the current program on the PLC, and to download a new program and system software to the PLC. The factory settings have the logging feature enabled and data is stored at 10 second intervals. This 32 GB card can store all currently configured registers at 10 second intervals for over 30 years. The data is stored in 24-hour interval .CSV files, with file names listed by date. The maximum allowed SD card size is 32 Gigabytes and uses the FAT32 format.

When an SD card is properly inserted and functioning properly, the SD status indicator will be steady “ON” with a quick blink to indicate data is being written at the log timer frequency set on the SD CARD DATALOGGING screen.

To enable or disable data logging on the SD card, press **[OK-HOLD]**, **[OK]**, **[RIGHT]** 4 times, **[UP]** or **[DOWN]**, **[OK]**. A value of 1 enables logging, while a value of 0 disables logging. The sequence is shown below:

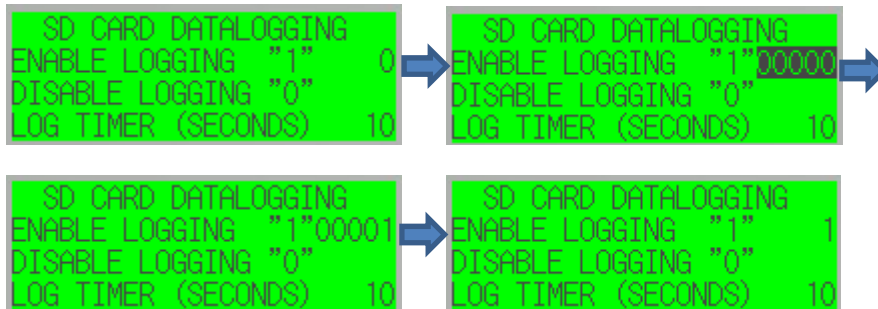

To change the frequency at which data is logged, press **[OK-HOLD]**, **[DOWN]**, **[OK]**, **[RIGHT]** to the appropriate numeral, **[UP]** or **[DOWN]** to the desired setting, **[OK]**. The sequence is shown below:

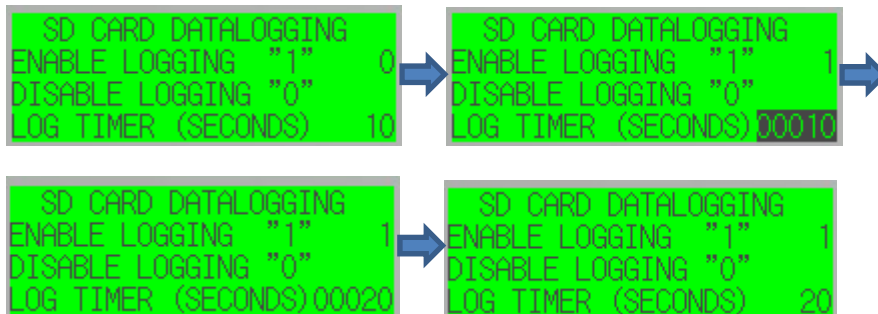

To eject the SD card, it's first recommended to disable data logging with the sequence above, then enter the system functions and stop access to the card. To stop the PLC from accessing the card, start at the home

screen, then press **[ESC-HOLD]** + **[OK-HOLD]** to access the system menu. The **[ESC]** button should be pressed slightly before the **[OK]** button is pressed. Scroll **[DOWN]** until the arrow points to the “External Memory” selection and press **[OK]**. Press **[OK]** to select “SD Card”. Press **[OK]** to select “Stop Access”. Scroll **[DOWN]** to select “Yes” press **[OK]**.

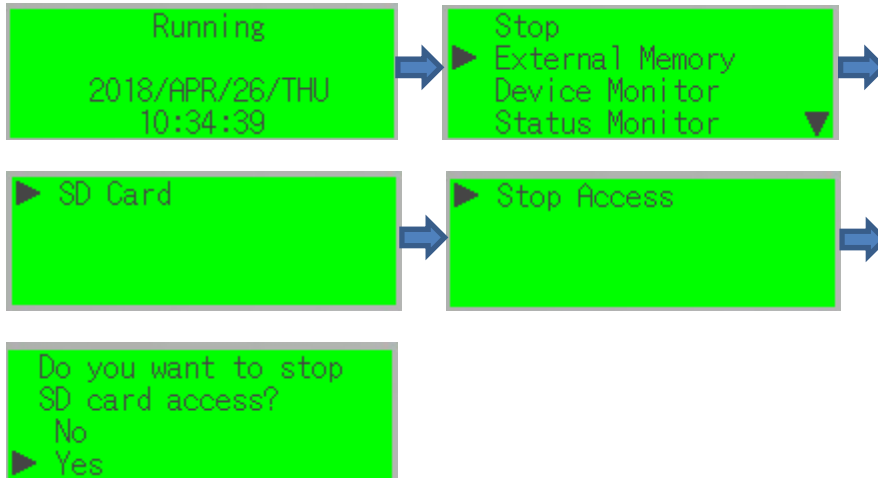

The PLC will show the hour glass for a few seconds, then return to the “Stop Access” screen when complete. The SD card may then be ejected safely from the PLC. This may be verified by the SD status indicator turned off.

An SD card may be installed at any time into the PLC, and write access will begin automatically. If there is an error with an inserted card, the SD status indicator will blink or be OFF.

An SD card may be used to download a new program into the PLC. This first requires a properly written program with the IDEC WINDLDR software, saving that program to a .ZLD extension file, and the proper folder structure on the card. If no folders exist on the card when it’s plugged in, the PLC will automatically create the required folders for logging data. This includes the top-level folder “FCDATA01” and subfolder “DATALOG”, where all .CSV files will be stored. If downloading program software, the “PROGRAM” subfolder will need to be created manually on the card, as this is where the PLC looks for the .ZLD files.

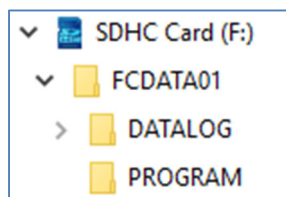

NOTE: It is highly recommended to record all settings in the PLC before updating the program or system software!

To download a new program and update the system software, stop the PLC, then download the file from the SD card. Start at the home screen, then press **[ESC-HOLD]** + **[OK-HOLD]** to access the system menu. The **[ESC]** button should be pressed slightly before the **[OK]** button is pressed. Select “Stop” on the menu, then **[OK]** and “Yes” and **[OK]**. Enter the system menu again, Scroll **[DOWN]** until the arrow points to the “External Memory” selection and press **[OK]**. Press **[OK]** to select “SD Card”. Scroll **[DOWN]** to “Program” and press **[OK]**. Press **[OK]** to select “Download”. Scroll **[DOWN]** to select the appropriate file name if there are more than one listed, then press **[OK]**. The PLC will download and update for approximately 1 minute, then return to the Download and Upload screen. **[ESC]** back and select “Run” to restart the PLC.



After the PLC program has been updated, run the “Reset Factory Register” command on the PLC (refer to section 5.2.11) and reconfigure all setpoints to any custom settings that may have been previously entered. The “Reset Factory Register” screen will also display the current software version of the PLC program.

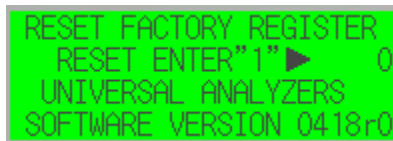

To check the current system software in the module, access the system menu and select “Status Monitor”. The CPU (PLC) software version and HMI software version will be listed.



5.2.14 System Clock and Battery

The system clock will be set from the factory and will not update for Daylight Savings Time. If the battery is replaced or the system clock needs to be corrected due to other reasons, “Stop” the PLC from the System menu, then select “Configurations” and then “Clock”. Follow the screen prompts to get it corrected.

If the PLC battery needs to be replaced, it’s accessible from the top of the PLC. This is a 3 Volt, 3/4” coin sized battery, BR2032. The battery may be replaced at any time. The PLC will list an Error in the system menu as a “Power Failure”, when the battery power has been consumed.

5.2.15 Modbus

The PLC is configured at the factory for Modbus RS485 from the serial port, and Modbus TCP/IP from the Ethernet port. The RS485 Modbus RTU Slave serial port is configured at the factory with the following parameters:

Baud Rate	115200
Data Bits	8
Parity	Even
Stop Bits	1
Slave Number	1
Max Cable Length	200m

The Ethernet port is configured at the factory for Modbus TCP with IP Address 192.168.1.1 and Local Host Port No. 502.

Modbus Registers

Register	Description	Value Type	Comment	PLC Address
40200	Sample Temp	Floating/R	Deg F	D0200
40202	Process Temp	Floating/R	Deg F	D0202
40204	Vortex Air Exhaust	Floating/R	Deg F	D0204
40206	Enclosure Temp	Floating/R	Deg F	D0206
40208	Sample Temp Setpoint	Floating/RW	Deg F	D0208
40212	Sample Hysteresis	Floating/RW	Deg F (Delta value)	D0212
40214	Sample Temp High Isolation	Floating/RW	Deg F (Delta value)	D0214
40216	Sample Temp Alarm Band	Floating/RW	Deg F (Delta value)	D0216
40316	Process Temp High Alarm	Floating/RW	Deg F	D0316
40325	Coolant Dwell Cycle ON Time	Word/RW	Seconds	D0324
40327	Coolant Dwell Cycle OFF Time	Word/RW	Seconds	D0326
40331	Reset to Factory Values	Word/RW	1 = Reset to Factory Defaults (resets itself to 0)	D0330
40336	Process Temp High Isolation	Floating/RW	Deg F	D0336
40339	Enclosure Temp	Word/R	Deg F	D0338
40345	Enclosure Low Alarm Setpoint	Word/RW	Deg F	D0344
40347	Enclosure High Alarm Setpoint	Word/RW	Deg F	D0346
40349	Enclosure Low Log	Word/R	Deg F	D0348
40351	Enclosure High Log	Word/R	Deg F	D0350
40353	Enclosure Log Reset	Word/RW	1 = Reset Enclosure Logs (resets itself to 0)	D0352
40701	Sample Valve Forced Open Bit	Word/RW	0 = Normal Operation 1 = Valve Open until Reset	D0700
40703	Sample Valve Forced Closed Bit	Word/RW	0 = Normal Operation 1 = Valve Closed until Reset	D0702
40705	Forced Bit Reset	Word/RW	1 = Reset Both Bits (resets itself to 0)	D0704

R= read only allowed

RW = read and write allowed

Output Coil Statuses

Coil	Description	Status	Comment	PLC Address
00001	Cooling Solenoid Valve	0 = Closed, 1 = Cooling	Enables Probe Cooling	Q0000
00002	Sample Solenoid Valve	0 = Closed, 1 = Open	Enables Sample Flow	Q0001
00003	General System Alarm	0 = Off, 1 = Alarm	Multiple Alarms Activate	Q0002
00004	Sample Temp Alarm	0 = Off, 1 = Alarm	Sample High/Low Temp Alarm	Q0003*
00005	Encl. Temp / Batt. Alarm	0 = Off, 1 = Alarm	Enclosure High/Low Temp and Battery Low Alarm	Q0004*
00006	High Process Temp	0 = Off, 1 = Alarm	Process High Temp Alarm	Q0005*
00007	Sample Valve Forced Open	0 = Off, 1 = Forced Open	Sample Valve Forced Open Bit	Q0006*

* These outputs are not wired to terminal blocks with standard units.

Input Statuses

Coil	Description	Status	Comment	PLC Address
10001	Sample Valve Forced Closed	0 = Off, 1 = Closed	Shutoff Sample Flow Valve	I0000

Serial Port Wiring

The following picture is as viewed from the front of the PLC.

No.	Signal Wire (RS-232C)	Signal Wire (RS485)
1	RD	-
2	SD	-
3	ER	-
4	-	A
5	-	B
6	DR	-
7	-	-
8	SG	SG
Shell*	Shield	Shield

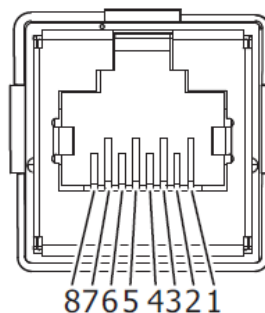

*Shell is connected to PE or FE on the power supply terminals

Note: RS232 communication is not supported by Universal Analyzers. The serial port may be configured to RS232 interface with IDEC WINDLDR software.

6.0 Start-Up

This procedure should be followed when starting up a Model 1221 Distillation Probe with vortex cooling. Proper startup procedures can take anywhere from 2 to 6 hours under normal conditions. Initialization times may vary depending on ambient conditions, process composition and temperature, and cooling medium quality.



Caution: Not following proper startup procedures can cause damage to probe equipment, analyzers, and possibly endanger personnel.

1. Ensure the probe is isolated from the process.
2. Sample flow to the analyzer should be bypassed.
3. Use compressed nitrogen to blow out any condensate from the sample tubing. Flow long enough to dry out the line and reconnect the tubing to the sample outlet in the control box.
4. Open the supply air valve. The supply air must be dry and free of particulate matter. Filtered instrument air (25-micron filter) with a dew point of at least -40°F is recommended.
5. If the probe was supplied with a pneumatic controller, ensure the air pressure regulator for the pneumatic controller is set to 40 psig. If the pneumatic timer is to be used, ensure the lockout valve is open and set the timer to the desired value. Close the manual sample shutoff ball valve.

If the probe was supplied with an electronic controller, the sample shutoff valve can be closed using the “FORCED CLOSED” feature on the PLC, or by installing a jumper across the “sample shutoff” contacts on the terminal strip.

6. Ensure the desired setpoint for the sample gas exiting the probe is set on the controller. The factory default is 65°F, unless otherwise specified during purchase.
7. If ambient conditions are above the sample setpoint, the probe should be cooled before introducing process gas. This should take 3 to 15 minutes, depending on conditions.
8. Thermometer and PLC RTD display can take a long time to indicate the actual internal column temperatures. This is due to the elements being suspended in free space and a lack of circulation of gasses in the column. It's possible for the piping to be at a much lower temperature than indicated, if the column is cooled for an extended time. Once gas is allowed to flow through the column and past the temperature sensors, a much more accurate reading will display. The thermometer or RTD may spike down in temperature as soon as the cold gas comes into contact with it. After the initial cooling period, it is recommended to pulse sample flow for approximately 10 seconds at a time to get cool gas to flow past each sensor. The process valve must be opened for this to occur. Repeat every couple of minutes until a pulse drops the temperature indications below the sample setpoint. If hot process gas is steadily flowed before the column is cool, the probe can heat soak and increase start times considerably.

For pneumatic controlled probes, the gas may be pulsed by opening and closing the manual sample shut off valve. The toggle valve is Normally Open, and unless the timer has been allowed to run down, the toggle valve should be open.

For electronic controlled probes, the “FORCED OPEN” feature on the PLC may be utilized to pulse gas flow. This feature will not work if the jumper is installed across the sample shutoff terminals. If the sample or process RTD alarms have activated and shut the sample flow toggle valve, the forced open command will override these alarms.

9. Once the unit is at the desired temperature, fully open the process isolation valve. For pneumatic controllers, open the manual sample shut off valve. For electronic controllers, reset the forced features or remove the shut off jumper. The cooling mechanism should start cycling on and off at regular intervals. The cooling sequence should cycle on/off one to two times in a ten-minute period.
10. Enable flow to the analyzer. Adjust the flow setting to between 1-5 LPM. Normal setting is 2 LPM.
11. The probe is now in service.



Caution: Once the process gases are introduced, the probe may become too hot to touch and may cause burns. Take adequate precautions when handling hot equipment. It's recommended that all equipment be checked for leaks after final installation.

7.0 Maintenance

It is recommended that each probe be installed with a gate valve to isolate from process for all maintenance activities.

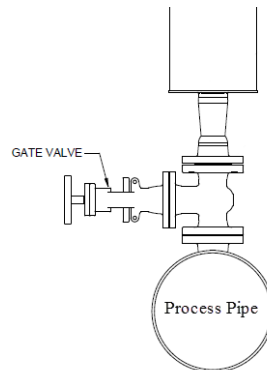

The coalescing separator is designed to condense and wash the heavy components in the sample back into the process along with any deposited solids avoiding the regular 'plugging' that occurs with conventional probes. For this reason, the separator is considered self-cleaning, and but should be inspected at regular intervals. Once isolated from the process pipe, the separator can be removed from the probe without the need to remove the entire probe body.

The separator may be removed in the field by removing the top blind flange, hooking the extractor tool through the lifting ring, and then pulling the assembly out. For electronic controllers, the sample and process inlet RTDs must be retracted before the separator may be removed. For pneumatic controllers, the thermometer must be retracted before the separator may be removed. The separator may then be cleaned and re-installed, or a clean, secondary separator may be used instead. The full procedure of cleaning the separator may be completed in 15-20 minutes.

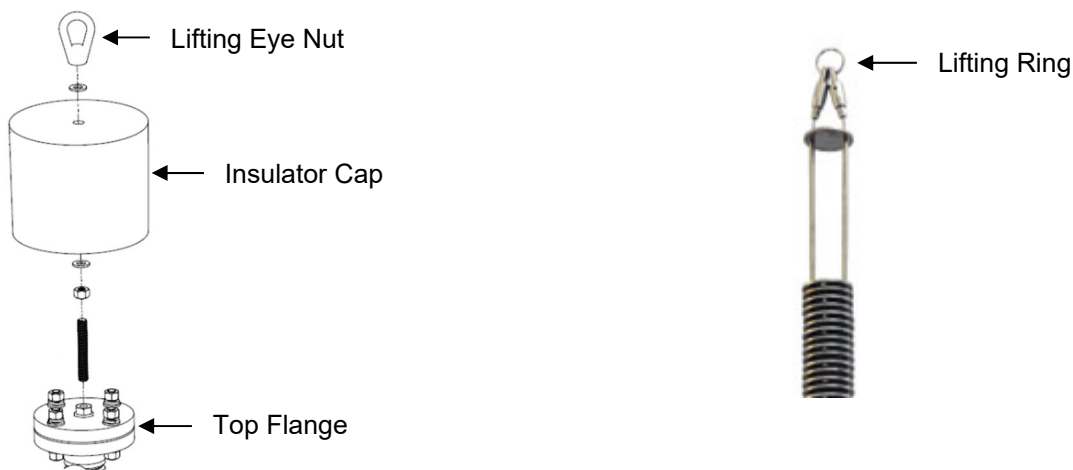

It is recommended to isolate sample flow from the probe during furnace maintenance activities which may cause damage to the probe or analytical equipment.



Caution: If the complete probe is to be removed from the process nozzle and/or gate valve, note that the probe can weigh as much as 150 lbs plus the weight of any remaining, trapped liquids inside. The eye nut and threaded stud should be inspected for tightness before lifting. Note that the eye nut is not directly over the center of gravity. Personnel may be exposed to any liquids trapped inside the probe.

8.0 Troubleshooting

- Ensure that vortex cooled probes are supplied with 40 SCFM air at 80-100 psig. Measurements to ensure this should be made at the probe, not at the supply header. Consider loss in pressure due to supply lines which may be inadequately sized diametrically and/or too long.
- Dual vortex cooled probes should be supplied with separate air supply lines for each vortex to avoid inadequate air supply. Each vortex requires 40 SCFM of air.
- Instrument air should be clean and dry, with a recommended dew point of less than -40°F. A 25-micron filter is recommended in air supply lines. Air which may condense moisture at higher levels may cause plugging in the vortex tubes, causing a sporadic cooling cycle. If moisture enters a pneumatic temperature controller, the sample temperature setpoint may shift substantially, and the unit should be removed from service and allowed to dry thoroughly and possibly re-calibrated.
- For pneumatic probes, the bleed tube has a 100-micron diameter hole which may become plugged from a variety of things, such as particulate in the supply air and external oils. Care should be taken to not touch the tip of the bleed tube with skin or any other object. If this becomes plugged, air pressure will bleed off too slowly, causing prolonged cooling cycles and possibly unwanted pneumatic timer valve shutoffs. The bleed tube may be removed and cleaned with alcohol.
- Locally Controlled (LC) probes have a limited operating temperature of 14F to 130F. In warm environments, do not install the control box in direct sunlight. An environmental purge is provided which allows instrument air to flow at approximately 1 liter/min to help cool the box. The LC probe should not be installed where ambient temperatures could drop below 14F or area classified heaters would be required. The Remote Controlled (RC) probes are preferred in both situations, where electronics may be installed in temperature-controlled shelters.
- Heated sample lines are the recommended method of transport. If a sample line is not heated, ambient temperatures below the sample setpoint can cause condensation to form in the tubing. If a sample line is not heated, the setpoint temperature should be lowered to keep it below all ambient conditions, if possible, without removing any necessary sample gases.

9.0 Drawings and Spare Parts

For the current revision of all Model 1221 drawings and spare parts, visit the Universal Analyzers website.

<https://www.universalanalyzers.com/>

Navigate to: Products -> Gas Sample Probes -> Model 1221

Links to all current drawings and spare parts for standard probe configurations are provided at the bottom of the page.

10.0 Standard Terms & Conditions of Sale and Warranty

THE FOLLOWING TERMS/CONDITIONS, TOGETHER WITH ANY OTHER TERMS/CONDITIONS SPECIFICALLY AGREED TO IN WRITING BY SELLER, SHALL APPLY TO ALL ORDERS ("Order(s)") FROM, AND SALES OF PRODUCTS ("Products") OR SERVICES ("Services") TO BUYER. ANY ACCEPTANCE OF ANY ORDER OF BUYER IS CONDITIONED UPON THESE TERMS/CONDITIONS. ANY ADDITIONAL OR DIFFERENT TERMS/CONDITIONS PROPOSED BY BUYER IN ANY DOCUMENT ARE OBJECTED TO AND SHALL NOT BE BINDING UPON SELLER. No salesperson is authorized to bind Seller to any promise or understanding not expressed herein.

I. PRICES

All prices are subject to change without notice in the event of any changes in cost of materials or labor, specifications, quantities, delivery schedules, customs duties, other factors beyond Seller's control, or in the event of delays caused by instructions of the Buyer, or failure of the Buyer to give Seller adequate information. Further, prices payable by the Buyer shall be subject to immediate increase, should the Seller as a result of governmental action or regulation including, without limitation, those contemplated by an investigation under Section 232 of the Trade Expansion Act of 1962 (19 U.S.C. §1862), incur additional duties, tariffs or restrictions on products sold hereunder, or on the raw materials that are used in making such products. In no event shall prices include any amounts imposed on the Buyer in connection with Buyer's purchases from Seller, such as taxes, including but not limited to Value Added Tax (VAT) or excise taxes, duties, tariffs, or any other costs assessed against the Buyer by a governmental authority.

II. DELIVERY

Delivery dates are approximate and are dependent on prompt receipt by Seller of all necessary information. Seller may deliver all or any part of Products/ Services as early as 30 days in advance of agreed schedule. The point of delivery shall be "Exworks" Seller's premises, unless otherwise specified by Seller. Upon delivery, title to Products and all risk of loss or damage thereto shall pass to Buyer. Where Buyer notifies Seller that it cannot take timely delivery of the Products, Seller may place such Products in storage, at the risk of Buyer, and Buyer shall reimburse Seller for all expenses incurred in connection with such storage. Buyer shall dispose of the packing materials for Products at its own expense, and shall defend, indemnify and hold harmless Seller from any legal obligations in connection with such packing waste.

III. PAYMENT

A. The term of payment shall be net 30 days from date of Seller's invoice, unless otherwise specified. Payments shall be made by Buyer without any deduction or set-off. Unless otherwise agreed, payment shall be made in U.S. dollars. Seller may charge late payment fees at the rate of 1.5% per month, or the highest rate permitted by law, whichever is less, accruing daily.

B. If the financial condition of Buyer is unsatisfactory to Seller, Seller may require full or partial payment in advance, or satisfactory security, in the form of a letter of

credit or otherwise. In the event of bankruptcy or insolvency of Buyer, Seller may immediately cancel any Order then outstanding.

C. Buyer grants Seller a purchase money security interest in Products located in the United States, or Services, as well as any proceeds, for the purpose of securing the obligations of Buyer hereunder. Buyer authorizes Seller to execute on Buyer's behalf and file such financing statements as Seller deems appropriate to perfect and notify Buyer's creditors of Seller's security interest.

IV. VARIATIONS IN QUANTITY; CHANGES.

Buyer shall accept delivery of quantities greater or smaller than the quantity specified in Order(s), provided that any such variation shall not exceed 5% of the quantity originally specified, or 2 units, whichever is greater. Seller shall not be required to give notice of any such variations other than in the applicable shipping notice and invoice. Seller reserves the option to make changes to Products or Services which do not affect form, fit, or function, and shall deliver Products to the latest configuration part number at the time of delivery.

V. EXPORT CONTROLS; FCPA; ANTI-BOYCOTT

A. Buyer shall not make any disposition of the Products, by way of transshipment, re-export, diversion or otherwise, except as applicable U.S. export laws and regulations may expressly permit, and other than in and to the ultimate country of destination specified on Order(s) or declared as the country of ultimate destination on Seller's invoices or in the End Use Statement that Buyer supplies Seller. Seller shall not be named as shipper or exporter of record or U.S. principal party-in-interest (USPPI) unless specifically agreed to in writing by Seller in which case, Buyer shall provide Seller with a copy of the documents filed by Buyer for Export clearance purposes. At Seller's request, Buyer shall supply end-use and end-user information to determine export license applicability. Failure of Buyer to comply with this section shall constitute a material default allowing Seller to cancel related Order(s) without liability.

B. Buyer warrants that it shall not violate or cause the Seller to violate the U.S. Foreign Corrupt Practices Act of 1977 (FCPA), as amended, the United Kingdom Bribery Act (UKBA) of 2010, as amended, or their respective implementing regulations in connection with Buyer's sale or distribution of the Products and/or Services, and that Buyer does not know or have reason to believe that any consultant, agent, representative or other person retained by Buyer in connection with the sale and/or distribution of Products/Services has violated, nor caused Seller to violate the FCPA and/or the UKBA. Where Buyer

learns of or has reason to know of any violation of FCPA and/or or UKBA in connection with the sale or distribution of Products/Services, Buyer shall immediately advise Seller.

C. Buyer further warrants that Buyer shall not violate or cause Seller to violate the U.S. Antiboycott Provisions of the U.S. Export Administration Regulations issued pursuant to the U.S. Export Administration Act of 1979, as amended, in connection with Buyer's purchase of Products/Services and that Buyer shall not request or require Seller to make statements or certifications against countries that are not subject to boycott by the U.S.

VI. WARRANTIES

A. Seller warrants that Products manufactured by Seller, when delivered, shall be free from defects in material/workmanship. Seller warrants that Services shall be performed in accordance with generally accepted industry practice. Seller's obligations under this warranty shall be limited exclusively to repairing or replacing, at Seller's option, any part of Products which, if properly installed, used and maintained, proved to have been defective in material or workmanship within 1 year from the date of shipment or re-performing the Services. Seller warrants for a period of 1 year from the date of shipment that software or firmware, when used with Products, shall perform in accordance with Seller's published specifications. Seller makes no warranty, express or implied, that the operations of the software or firmware shall be uninterrupted or error-free, or that functions contained therein shall meet or satisfy the Buyer's intended use/requirements. Buyer shall notify Seller of any defect in the quality or condition of Products (including software/firmware) or Services within 7 days of the date of delivery or performance, unless the defect was not apparent on reasonable inspection, in which case, within 7 days after discovery of the defect. If Buyer does not provide such timely notification, it shall not be entitled to reject Products (including software/firmware) or Services, and Seller shall have no liability for such defect.

B. Seller's warranty obligations shall not apply to Products which (1) have been altered or repaired by someone other than Seller, or (2) have been subjected to misuse, neglect, or improper use or application, or (3) are normally consumed in operation, or (4) have a normal life inherently shorter than the warranty period stated therein.

C. No Products may be returned unless authorized in advance by Seller, and then only upon such conditions to which Seller may agree. Buyer must obtain a Return Material Authorization (RMA) number from Seller prior to any return shipment, and such RMA number must appear on the shipping label and packing slip. Buyer shall be responsible for returned Products until such time as Seller receives the same at its facility, and for all charges for packing, inspection, shipping, transportation or insurance associated with returned Products.

D. This section VI sets forth the exclusive remedies and obligations for claims based upon defects in or nonconformity of Products/Services, whether the claim is in contract, warranty, tort (including negligence of any degree or strict liability) or otherwise. THE FOREGOING WARRANTIES ARE IN LIEU OF ALL OTHER WARRANTIES, WHETHER ORAL, WRITTEN, EXPRESS, IMPLIED OR STATUTORY. NO IMPLIED OR STATUTORY WARRANTIES OF MERCHANTABILITY OR FITNESS FOR PARTICULAR PURPOSE SHALL APPLY.

VII. PATENTS/INDEMNITY

If Buyer receives a claim that Products, or part thereof manufactured by Seller infringes a patent, Buyer shall notify Seller promptly in writing and give Seller information, assistance and exclusive authority to evaluate, defend and settle such claim. Where Buyer has furnished specifications/designs for the manufacture of the allegedly infringing Products, Buyer shall defend, indemnify and hold harmless Seller against third-party claims for infringement arising out of Seller's use of such specifications/designs.

VIII. LIMITATION OF LIABILITY

The total liability of Seller on any claim, whether in contract, tort (including negligence of any degree and strict liability) or otherwise arising out of, connected with, or resulting from the manufacture, sale, delivery, resale, repair, replacement or use of any Products/Services, shall not exceed the price allocable to the Products/Services or part thereof which gives rise to the claim. IN NO EVENT, WHETHER AS A RESULT OF BREACH OF CONTRACT, WARRANTY, TORT, (INCLUDING NEGLIGENCE OF ANY DEGREE, STRICT LIABILITY OR PATENT INFRINGEMENT) OR OTHERWISE, SHALL SELLER, ITS AFFILIATES, SUBCONTRACTORS, OR SUPPLIERS BE LIABLE FOR ANY LOSS OF PROFIT OR REVENUES, LOSS OF USE OF THE PRODUCTS OR SERVICES, OR ANY ASSOCIATED EQUIPMENT, COST OF CAPITAL, COST OF SUBSTITUTE GOODS, FACILITIES, SERVICES OR REPLACEMENT POWER, DOWNTIME COSTS OR CLAIMS OF BUYER'S CUSTOMERS FOR DAMAGES OR FOR ANY SPECIAL, PROXIMATE, CONSEQUENTIAL, INCIDENTAL, INDIRECT OR EXEMPLARY DAMAGES. If Buyer transfers title to, or leases Products sold hereunder to, or otherwise permits or suffers use by, any third party, Buyer shall obtain from such third party a provision affording Seller and its subcontractors/suppliers the protection of the preceding sentence. Any action against Seller must be brought within 18 months after cause of action accrues.

IX. EXCUSABLE DELAYS

A. Seller shall not be liable for delays in delivery or failure to perform due directly or indirectly to causes beyond Seller's reasonable control including but not limited to: acts of God; war; terrorism; civil commotion; riots; embargoes; government regulations, orders, instructions or priorities; port congestion; acts of or failure to act on the part of Buyer or its agents/employees; fires; floods; sabotage; nuclear incidents; earthquakes; storms; epidemics; strikes; lockouts or other labor difficulties; shortages of or inability to timely obtain proper labor, materials, components, shipping space or transportation, fuel, supplies or power at current prices; or due to limitations imposed by the extent of availability of Seller's normal manufacturing facilities.

B. If a delay excused per the above extends for more than 90 days and the parties have not agreed upon a revised basis for continuing providing Products/Services at the end of the delay, including adjustment of the price, then either party (except where delay is caused by Buyer, in which event only Seller) upon thirty (30) days' notice may terminate the Order with respect to the unexecuted portion of the Products/Services, whereupon Buyer shall promptly pay Seller its reasonable termination charges upon submission of Seller's invoices thereof.

X. SOFTWARE/TECHNICAL/PROPRIETARY INFORMATION

A. Buyer shall not acquire any rights to any software which may be delivered with Products, except as granted in Seller's standard software license. Any software license granted in connection with Products shall be an interim license, which may be withdrawn, pending payment for Products in full.

B. The purchase of Products shall not include any right to supply of technical information such as drawings or specifications.

C. Proprietary information, including drawings, documents, technical data, reports, software, designs, inventions and other technical information supplied by Seller in connection herewith (hereinafter called "Data"), shall remain Seller's sole property and shall be held in confidence by Buyer. Data shall not be reproduced, used or disclosed to others by Buyer without Seller's prior written consent. Upon completion of Order, Buyer shall promptly return all Data to Seller together with all copies or reprints thereof then in Buyer's possession or control, and Buyer shall thereafter make no future use, either directly or indirectly, of any Data or any information derived therefrom without Seller's prior written consent. The foregoing shall in no way obligate Seller to provide or supply Data.

XI. DIES, TOOLS, PATTERNS

Seller's charges for dies, molds, patterns and the like represent the Buyer's proportionate cost thereof, it being expressly understood that they remain the property of Seller.

Modifications made to dies, molds, patterns and the like in order to manufacture Products shall be at the discretion of Seller.

XII. GENERAL

A. The rights and obligations of the Buyer and Seller hereunder shall be governed in all respects by the law of the Commonwealth of Pennsylvania, U.S.A. The exclusive forum for adjudication of any disputes shall be the federal or state courts of the Commonwealth of Pennsylvania, and Buyer/Seller hereby consent to personal jurisdiction and venue in such courts in any proceeding. The United Nations Convention on the International Sale of Goods shall not apply.

B. These Terms and Conditions of Sale together with any other terms specifically agreed to in writing by Seller constitute the entire agreement between Buyer and Seller and supersede any prior or contemporaneous representations, agreements, proposals, warranties, or understandings, oral or written, express or implied. No waiver, modification, amendment, rescission or other change to these Terms and Conditions of Sale shall be binding unless specifically agreed to in writing by an authorized representative of Seller.

C. The invalidity, of any part hereof shall not affect the validity of the remainder. The failure of Seller to assert any right at any time hereunder shall not prevent Seller's subsequent assertion of the same or different rights.

D. Buyer may not assign this contract without the prior written approval of the Seller.

XIII. PROHIBITION FOR HAZARDOUS USE

Products sold hereunder are not intended for application in, and shall not be used by Buyer in construction or application of a nuclear installation or in connection with use or handling of nuclear material or for any hazardous activity or critical application, where failure of a single component could cause substantial harm to persons or property, unless Products have been specifically approved for such activity or application.

Seller disclaims all liability for loss or damage resulting from such unauthorized use and Buyer shall defend, hold harmless and indemnify Seller against any such liability, whether arising

under breach of contract, warranty, tort (regardless of the degree of fault or negligence), strict liability or otherwise. Where Seller approves the application of the Products in a nuclear facility, the Buyer shall, before such use or provision, arrange for insurance or governmental indemnity protecting the Seller against liability and hereby releases and agrees to indemnify the Seller and its suppliers for any nuclear damage, including loss of use, in any manner arising out of a nuclear incident, whether alleged to be due, in whole or in part to the negligence or otherwise of the Seller or its suppliers.

XIV. STATUTORY REQUIREMENTS

Seller reserves the right to make any changes in the general specifications of the Products which are required for the Products to conform to any statutory requirement.

XV. GOVERNMENT CONTRACTS

Only Federal Acquisition Regulation ("FAR") supplement clauses expressly accepted in writing by Seller shall be included or incorporated by reference herein. Seller shall not be bound by and makes no representation of compliance with any FAR or FAR supplement clauses that Seller shall not have expressly accepted in writing.